



## Operator's Manual

RenalGuard Solutions, Inc.  
459 Fortune Blvd  
Milford, MA 01757  
Phone: 508-541-8800  
Fax: 508-541-6768



La00264, Rev O

These instructions, as well as the hardware and software described, are furnished under license and may be used or copied only in accordance with the terms of such license. The contents are furnished for informational use only. Due to continuing product improvement, specifications are subject to change without notice. Changes to these instructions are accomplished through reissue. If you find any errors, omissions, or incorrect data, please inform the RenalGuard Solutions, Inc. technical support department.

RenalGuard is manufactured by CardioRenal Systems, Inc. the parent company of RenalGuard Solutions, Inc.

RenalGuard Solutions, Inc.  
459 Fortune Blvd  
Milford, MA 01757 USA



Made in U.S.A.

**Copyright** © 2021 RenalGuard Solutions, Inc. All rights reserved.  
Printed in the United States of America.

**Patents** Protected by US and Foreign Patents See: Pat. <http://www.renalguard.com/ip>

**Trademarks** RenalGuard and RenalGuard Logo are trademarks of CardioRenal Systems, Inc.

RenalGuard Solutions logo is a trademark of RenalGuard Solutions, Inc.

**Technical Support** For technical support contact RenalGuard Solutions:  
Toll-free (U.S. and Canada): 1-800-232-8422  
International: + 1-508-541-8800  
Fax: + 1-508-541-6768



**Manufacturer's Representative In the European Union** PLC Systemas Medicos Internacionais GmbH  
Borsteler Chaussee 55  
22453 Hamburg Germany  
Telephone: (49) 40 450 3220  
Facsimile: (49) 40 400 3221

## Table of Contents

<b>1.</b>	<b>Introduction.....</b>	<b>6</b>
<b>2.</b>	<b>Before You Get Started .....</b>	<b>7</b>
<b>2.1</b>	<b>Indications for Use .....</b>	<b>7</b>
<b>2.2</b>	<b>Environment of Use .....</b>	<b>7</b>
<b>2.3</b>	<b>Compatibility.....</b>	<b>8</b>
<b>2.4</b>	<b>Warnings and Cautions:.....</b>	<b>9</b>
<b>2.5</b>	<b>System Components .....</b>	<b>14</b>
<b>2.6</b>	<b>Electrical Requirements .....</b>	<b>15</b>
<b>2.7</b>	<b>Battery Replacement Procedure .....</b>	<b>16</b>
<b>2.8</b>	<b>Calibration Requirements .....</b>	<b>17</b>
<b>2.9</b>	<b>Placement Requirements .....</b>	<b>18</b>
<b>2.10</b>	<b>Cleaning.....</b>	<b>19</b>
<b>2.10.1</b>	<b>Cleaning the Touchscreen Display .....</b>	<b>19</b>
<b>2.10.2</b>	<b>Cleaning the Console and Cart Surfaces .....</b>	<b>19</b>
<b>2.11</b>	<b>Symbols .....</b>	<b>21</b>
<b>2.12</b>	<b>Label Images.....</b>	<b>23</b>
<b>2.13</b>	<b>Abbreviations.....</b>	<b>25</b>
<b>2.14</b>	<b>Service Information .....</b>	<b>25</b>
<b>2.15</b>	<b>Disposal of Waste Electrical and Electronic Equipment .....</b>	<b>26</b>
<b>3.</b>	<b>Device Description .....</b>	<b>27</b>
<b>3.1</b>	<b>Theory of Operation .....</b>	<b>27</b>
<b>3.2</b>	<b>RenalGuard System Overview .....</b>	<b>27</b>
<b>3.3</b>	<b>System Display .....</b>	<b>28</b>
<b>3.4</b>	<b>User Settings .....</b>	<b>29</b>
<b>3.5</b>	<b>Safety Features .....</b>	<b>30</b>
<b>3.6</b>	<b>Audio Indicators.....</b>	<b>31</b>
<b>4</b>	<b>Operation.....</b>	<b>32</b>
<b>4.1</b>	<b>Features.....</b>	<b>32</b>
<b>4.2</b>	<b>Installation and Setup.....</b>	<b>34</b>
<b>4.2.1</b>	<b>Console Unpacking and Initial Inspection .....</b>	<b>34</b>
<b>4.2.2</b>	<b>Cart Unpacking, Inspection and Assembly.....</b>	<b>35</b>
<b>4.2.3</b>	<b>Initial Setup .....</b>	<b>37</b>

4.2.4	Powering Down and Storage .....	38
4.2.5	Charging the Battery .....	38
4.3	Therapy Setup .....	39
4.4	Loading the Infusion Set .....	40
4.5	Priming the RenalGuard Single Use Set .....	41
4.6	Connecting the RenalGuard System to the Patient .....	44
4.7	Setting and Changing Parameters .....	45
4.7.1	Infusion Menu .....	46
4.7.1.1	Bolus Deliver Setting .....	46
4.7.1.2	Minimum Hydration Rate Setting .....	46
4.7.2	Fluid Balance Menu .....	47
4.7.2.1	Desired Fluid Balance Setting.....	47
4.7.2.2	Other Fluid Intake Setting .....	47
4.7.3	Percent Match Menu .....	48
4.7.3.1	Percent Match Setting.....	48
4.7.4	Alert Settings Menu .....	48
4.7.4.1	Minimum Urine Output Setting .....	48
4.7.4.2	Negative Alert Limit Setting .....	48
4.7.4.3	Positive Alert Limit Setting.....	49
4.8	Initiation of Therapy .....	49
4.9	Using Pause Mode .....	50
4.10	Using Advance Mode .....	51
4.11	Replacing the Hydration Fluid Bag .....	51
4.12	Emptying the Urine Collection Bag.....	53
4.13	Conclusion of Therapy .....	53
4.14	De-Installation and Packaging .....	54
4.15	Hourly Fluid Balance Table Screen .....	55
5	Alarms and Troubleshooting.....	56
5.1	Therapy Information Alerts .....	57
5.2	Fluid Path Related Alarms and Alerts .....	58
5.3	System Malfunctions .....	66
6	Technical Information .....	68
6.1	Console Specifications .....	68

**6.2 Guidance and Manufacturer's Declaration.....71**  
**7 Warranty.....74**

## 1. Introduction

This Operator's Manual provides instructions necessary for the proper operation of the RenalGuard Solutions, Inc. (RGS) RenalGuard System™. It is not a guide to appropriate medical care. The use of the RenalGuard System and effective fluid management depends primarily upon the medical skills and knowledge of the medical team. Consequently, technical competence in operation of the RenalGuard System must be supplemented by a thorough understanding of the associated medical procedures.

The RenalGuard System maintains the vascular volume by measuring patient urine output and infusing hydration fluid (prescribed by physician) into the patients IV to balance the fluid volume lost in urine.

The RenalGuard System consists of:

- the RenalGuard Console (Console),
- the RenalGuard Cart (Cart), and
- the RenalGuard Single Use Set (Set) that includes an Infusion Set and a Collection Set with an integrated urine collection bag.

The RenalGuard System neither controls nor regulates the patient's overall fluid or electrolyte balance. Total fluid balance includes all fluid intake (oral or IV) as well as all fluid output (feces, urine, chest tube or other drainage, etc.). It is the responsibility of the attending physician and the user to achieve the intended clinical results with proper choice of hydration rate, monitoring of appropriate clinical and laboratory data and any required concomitant pharmacological therapy to achieve appropriate hydration status and effective treatment.

Patient treatment must, at all times, be in accordance with the specific procedures prescribed by a qualified physician. Users must operate the RenalGuard System in accordance with the information detailed in this manual. RGS offers training in the use of the RenalGuard System based upon the contents of this operator's manual.

## 2. Before You Get Started

### 2.1 Indications for Use

The RenalGuard System is indicated for temporary<sup>1</sup> replacement of urine output by infusion of a matched volume of sterile replacement solution to maintain a patient's intravascular fluid volume.

The RenalGuard System is not intended for infusion of blood, blood components, medications, or nutritional fluids.

All treatments administered via The RenalGuard System must be prescribed by a physician.

### 2.2 Environment of Use

The RenalGuard System is intended to be used in a monitored hospital environment, such as an interventional lab or an intensive care unit, by medical personnel instructed in the use of the device.

---

<sup>1</sup> The RenalGuard System™ is intended for use no longer than 14 days with one patient. Individual RenalGuard Single Use Sets should not be used longer than 72 hours.

## 2.3 Compatibility

The RenalGuard System is designed to operate with:

1. All standard adult indwelling or short term urinary Foley catheters indicated for drainage of urinary bladder. (i.e. 16Fr Bard Foley catheter).
2. IV infusion needles and cannula intended for infusion of fluids into surface peripheral veins at rates of up to 6 liters/hour. It is required that needle sizes of Gauge 20 or larger bore size are used to prevent excessive resistance to flow (i.e. 20G BD Insyte™ Autoguard™). Use of smaller needles can result in alarms and suboptimal performance of the System.
3. Compatible fluids include crystalloid or colloid IV fluids in standard one liter bags. Incompatible fluids include medications, blood products and non-ionic fluids. Use of bags that are size other than 1 liter will result in alarms and suboptimal performance of the System. It is the responsibility of the prescribing physician to choose the appropriate fluid composition.
4. The Infusion Set is equipped with standard needle-less infusion port that can be used to connect to standard syringes and IV infusion sets. It is the responsibility of the prescribing physician and medical personnel operating the System to choose the appropriate infusion fluid and rate, control air bubbles and maintain sterility.

**Caution:** *The RenalGuard System is designed for use with 1 (one) liter infusion bags only. The System will not operate properly with other sized infusion bags.*

**Warning:** *The RenalGuard Infusion Set can only be used with the RenalGuard console. It cannot be used with any other device or as a standalone infusion set.*

## 2.4 Warnings and Cautions:

This manual contains important information concerning the prevention of bodily injury and the protection of the equipment. Such information may be designated as either Warning or Caution whereby:



Warning - designates information concerning the possibility of bodily injury to the patient, operator, or other individuals.

Caution - designates information concerning the possibility of damage to the equipment or to other property.

- Carefully read all warnings, precautions, and instructions before use. Follow all operating, maintenance, and installation procedures as described in this manual. Failure to do so can result in patient harm.
- RenalGuard Solutions, Inc. will not be responsible for patient safety if the procedures followed to operate, maintain, and calibrate the RenalGuard System are other than those specified in this manual. Anyone who performs the procedures must be appropriately trained and qualified.
- Use of accessory equipment not approved by RGS can result in patient injury or death.
- All electrical installations must comply with all applicable local electrical code and the manufacturer's specifications. Grounding reliability can only be achieved when the equipment is connected to an equivalent receptacle marked "HOSPITAL ONLY" or "HOSPITAL GRADE". Use potential equalization (ground post) in accordance with national requirements. If the grounding reliability of the power cord is suspect, the cord must be replaced with an equivalent power cord with a receptacle marked "Hospital Only" prior to operating the equipment.
- All fluid flow paths in the RenalGuard Single Use Set are sterile and non-pyrogenic. Aseptic technique must be used throughout the procedure. Usual and customary infection control practices should be followed when replacing the Set to ensure the safety of the patient and clinician. Dispose of any residual fluids and urine remaining in the Set appropriately.
- Use only RenalGuard Single Use Sets with the RenalGuard Console. To prevent contamination, the Set must be used as soon as its package and sterilization caps are removed. Do not use the RenalGuard Single Use Set if the package is damaged, if the sterilization caps are missing or loose, or if the lines are kinked. Destroy the Set after a single use, using appropriate procedures for potentially contaminated material. Do not re-sterilize.
- The RenalGuard System is designed for use with 1 (one) liter infusion bags only. The System will not operate properly with other sized infusion bags.

- The RenalGuard Single Use Set's intended duration of use is up to 72 hrs. After 72 hours, replace the Single Use Set and re-run Prime on the new set. This can be repeated with one patient up to a total of 14 days, at which time use of the RenalGuard System must be discontinued.
- The use of other than RGS RenalGuard Infusion Sets or Collection Sets can result in patient injury.
- The RenalGuard Infusion Set can only be used with the RenalGuard console. It cannot be used with any other device or as a standalone infusion set.
- After use, the RenalGuard Single Use Set may be a potential biohazard. Handle and dispose of Infusion and Collection Sets in accordance with standard medical practice and applicable local, state and federal laws and regulations.
- During priming and operation, observe closely for leakage at joints and connections. If tightening the connections cannot stop leakage, replace the entire Set.
- Do not allow air to enter the RenalGuard Single Use Set after priming. If a large amount of air has entered and cannot be removed, the Set must be replaced.
- The Console may not be able to detect disconnections or occlusions of the Foley connector, urine set tubing, infusion tubing and/or venous access catheters. Carefully observe the RenalGuard Single Use Set and all operations of the RenalGuard System during patient treatment.
- The RenalGuard System uses positive displacement to infuse hydration fluid. If "gravity flow" infusion systems are attached to the infusion ports of a RenalGuard Single Use Set or to a common IV site, the flow of the "gravity only" infusion system may be impeded. Attaching additional infusion sets to the RenalGuard Single Use Set or to a common IV site risks infusing air into the patient. Hospital personnel should follow standard procedures for using "gravity flow" infusion systems in combination with positive displacement pumps. They should also ensure the accuracy of any additional infusion sets attached to the RenalGuard Single Use Set or to a common IV site.
- Do not modify the RenalGuard System in any way.
- Do not attempt to service any part of the RenalGuard System. Refer servicing to RenalGuard Solutions personnel only. If non-RenalGuard Solutions personnel perform repairs or adjustments, RenalGuard Solutions cannot guarantee the safety, reliability and performance of the system.
- **ELECTRIC SHOCK HAZARD.** Do not open the case of the RenalGuard Console due to the risk of electrical shock from the AC power or the internal batteries.

- Do not operate the RenalGuard System in the presence of flammable anesthetics or volatile substances, such as alcohol or elevated levels of oxygen. Under no circumstances should flammable gases be present when operating the RenalGuard System.
  - Equipment that generates high energy radio interference (cables, cellular phones, portable radios, electrosurgical equipment, etc) can cause false alarms and should be used no closer than 30cm (12 inches) to the RG console . If this occurs, reposition the RenalGuard Console away from the source of interference and restart therapy. No other electrical equipment is to be stacked on the RG console or cart.
  - Store the RenalGuard Single Use Set in a dry place, between 12°C (59°F) and 29°C (85°F).
  - Congestive Heart Failure (CHF) or patients under sedation are at elevated risk of fluid overload and pulmonary edema, and therefore should be monitored closely when connected to the RenalGuard System.
  - Patients with high urine flows are at risk of electrolyte imbalance and should be observed for these signs or symptoms of fluid or electrolyte imbalance: dryness of mouth, thirst, weakness, lethargy, drowsiness, restlessness, muscle pains, cramps, muscular fatigue, hypotension, oliguria, tachycardia, arrhythmia, or gastrointestinal disturbances such as nausea and vomiting.
- 
- The urine collection bag must be below the level of the patient's bladder to facilitate urine drainage.
  - Potential hazards can exist if similar equipment with similar alarms settings are being used in the same area. If possible, adjust other equipment alarm pre-sets to operate in a different manner to prevent confusion

Additional warnings or cautions applicable to specific sections of this manual are replicated in the following table:

Section	Warning or Caution Text
§ 2.3, § 4.4, § 4.12	<b>Caution:</b> <i>The RenalGuard System is designed for use with 1 (one) liter infusion bags only. The System will not operate properly with other sized infusion bags.</i>
§ 2.3, § 2.8	<b>Warning:</b> <i>The RenalGuard Infusion Set can only be used with the RenalGuard console. It cannot be used with any other device or as a standalone infusion set.</i>
§ 2.8	<b>Caution:</b> <i>Installing the RenalGuard Console on anything other than the RenalGuard Cart may introduce a hazardous situation. For example, installation on an IV pole that allows the upper portion of the pole to rotate separately from the lower half of the pole can interfere with the Console's ability to measure urine volume.</i>
§ 2.9	<b>Caution:</b> <i>Exercise care during cleaning to ensure that liquids do not enter the Console. (The RenalGuard Console has been tested per IEC 60529 IPX2 to be resistant to vertically dripping fluids but is not liquid-tight.)</i>

Section	Warning or Caution Text
§ 4.3	<b>Caution:</b> The RenalGuard Console should be plugged in at all times. Failure to do so may result in decreased battery operation time.
§ 4.4	<b>Warning:</b> The RenalGuard System will not operate properly if the urine bag is not hanging freely on the weight scale chain, or is interfered with in any way.
§ 4.6	<b>Warning:</b> The urine collection bag must be below the level of the patient's bladder to facilitate urine drainage
§ 4.5	<b>Caution:</b> It is necessary to complete the priming procedure before connecting the patient for therapy. The RenalGuard Console performs required safety checks during the priming procedure.
	<b>Warning:</b> Do not connect the patient to the Infusion Set during the priming procedure. The air detector is disabled during priming. This could result in air being introduced into the patient.
	<b>Caution:</b> The RenalGuard Single Use Set can only be primed using the following automatic priming procedure.
§ 4.5, § 4.11, § 5.2	<b>Warning:</b> Air detection is disabled during <b>Advance</b> button operation. The <b>Advance</b> button must not be pressed while the Infusion Set is connected to the patient.
§ 4.6	<b>Warning:</b> Aseptic technique must be used throughout the procedure. Usual and customary hospital infection control practices should be followed when replacing the patient connected tubing to ensure the safety of the patient and clinician.
	<b>Warning:</b> Automatic air detection is disabled during manual connection operations.
§ 4.7	<b>Warning:</b> The RenalGuard System does not measure the total volume removed from or infused into the patient. The System only measures the urine output and system hydration rate. It is the user's responsibility monitor the patient's overall hydration status. If other fluids are infused or removed, the user is responsible for keeping track of the total amount of fluid infused or given orally.
§ 4.7	<b>Warning:</b> This setting relies on the user input to calculate the total volume of fluid infused into the patient from other sources. It is the user's responsibility to adjust this setting if the other infusion rates are adjusted or terminated.
§ 4.7.1.2	<b>Warning:</b> Both of these settings can cause the RenalGuard System to infuse fluid over and above the patient's urine output volume. It is the user's responsibility to confirm that this is an appropriate fluid balance for the patient.
§ 4.7.2.1	<b>Caution:</b> This setting will cause the RenalGuard Console to infuse fluid either above or below the patient's urine output volume. It is the user's responsibility to confirm that this is an appropriate fluid balance for the patient.
§ 4.7.2.2	<b>Caution:</b> This setting relies on the user input to calculate the total volume of fluid intake from other sources. It is the user's responsibility to adjust this setting if the other intake rates are adjusted or terminated.
§ 4.8	<b>Warning:</b> Running with the infusion line clamped or leaving the Console in Stop mode risks underinfusing the patient and increases the risk of thrombosis.
§ 4.9	<b>Caution:</b> When the RenalGuard Console is in Pause mode, the Urine volume output is not being replaced. The Infusion rate is set to the minimum hydration rate until the user terminates Pause mode.
	<b>Caution:</b> Stay in Pause mode no more than is necessary. After the urine bag is drained in Pause mode, urine is not measured by the Console until Run mode is resumed. Resume Run mode as soon as possible after draining bag to ensure accurate urine measurement.
§ 4.11	<b>Warning:</b> The RenalGuard System is designed for hydration with crystalloid and colloid hydration fluids only. It is not designed to infuse blood, blood products, or to deliver drugs.
§ 4.12	<b>Caution:</b> Emptying the Urine Collection Bag during Run or Stop mode, or while the Console is powered off may result in incorrect urine measurement and alarms.

Section	Warning or Caution Text
§ 5.0	<b>Warning:</b> <i>Silencing and Clearing an Alarm may not eliminate the Alarm cause. Carefully investigate and correct all Alarms and Alerts.</i>
	<b>Caution:</b> <i>While the RenalGuard Console will provide information on the most likely causes of the alarm, the user must exercise caution and examine all possible options if the information displayed does not solve the problem.</i>
§ 5.2	<b>Warning:</b> <i>It is the user's responsibility to ensure that air is removed from the infusion circuit before the system is restarted following air detection.</i>
	<b>Caution:</b> <i>Always enter Pause mode prior to draining urine. Remember to close the drain valve. Press the Run button again to resume therapy.</i>
	<b>Caution:</b> <i>Whenever the RenalGuard System is in the Pause mode, urine volume is not being replaced. The patient receives the user set minimum rate of hydration.</i>

## 2.5 System Components

The RenalGuard System consists of the Console, the Cart and RenalGuard Single Use Sets for infusion and urine collection.

Each Console is packaged with the following items:

- a detachable power cord
- a chain for suspending the infusion bag
- a chain for suspending the collection bag
- 2 chain guide tubes (only with Consoles that do not have permanently attached chains)
- an operator's manual

Each RenalGuard Cart is packaged with the following items:

- a pole
- base with casters
- handle with clamp
- 2 bag holders
- chain guide & tubing holder
- basket
- miscellaneous hardware
- assembly instructions

Each RenalGuard Single Use Set includes:

- an integrated Infusion Set with an IV bag spike
- a Luer-to-Foley connector for priming
- a urine Collection Set with an integrated urine bag
- a 3 foot extension set for the urine Collection Set
- directions for use

## 2.6 Electrical Requirements

The RenalGuard Console is supplied with a detachable power cord fitted with a hospital-grade plug.

- Power the Console only by a properly protected and grounded electrical supply that meets the following requirements: 100 - 240 VAC, 60/50 Hz, 100 VA
- Plug the power cord into an outlet labeled 'Hospital Only' or 'Hospital Grade' to ensure grounding reliability. If the grounding reliability of the power cord is suspect, the cord must be replaced with an equivalent power cord using a receptacle marked "Hospital Only" prior to operating the equipment.
- For non-US installations, an appropriate power cord satisfying local code and configuration requirements must be provided by the installing facility.

Fusing options within the power entry module:

- The power entry module incorporates a dual fuse carrier that will meet electrical safety requirements where both sides of the input line must be fused.
- For US (115 VAC) installations where electrical safety requirements dictate a single fuse on the input line, a removable metal clip occupies one of the two fuse locations.
- The fusing option that will satisfy local code requirements must be determined by the installing facility.

Other electrical connections include:

- An auxiliary ground post (potential equalization) for the device is on the rear panel.
- An RS-232 port intended for use by service personnel only. This connection is not designed to interface with any other hospital equipment.

## 2.7 Battery Replacement Procedure

Battery replacement should only be performed by trained service personnel. Should you need to replace the battery the following steps are to be performed

- Disconnect power cord from console and remove the 10 Philips head screws which hold the rear enclosure on.
- Slide the rear enclosure up and off the RG console
- The battery compartment door is located at the bottom of the frame. Remove the two Phillips head screws holding door on.
- Loosen the 1/16" Allen head screw on the side of the frame to allow the battery to slide out of its holder.
- Remove the battery by pulling on its access tab and slide the battery completely out of its holder.
- Install only a RGS supplied replacement battery by sliding new battery back into the holder.
- Make sure the battery seats into the electrical connection at top of holder.
- Carefully tighten the Allen screw to hold the battery in place
- Reconnect battery door, and rear enclosure.

## 2.8 Calibration Requirements

The RenalGuard Console operates by continuously monitoring the weights of the infusion bag and the collection bag and adjusting the performance of the pump in accordance to the user's instructions. Calibration of the internal weight scales is recommended once a year.

Calibration should only be performed by individuals familiar with adjusting medical equipment settings. Contact your service representative (refer to section 2.14 Service Information) for further information before proceeding.

Two hook weights each calibrated to the appropriate national standard and capable of being suspended from either the infusion bag or collection bag chain will be required to perform the calibration:

- a 1 kg weight
- a 2 kg weight

Weight scale calibration is performed by entering the Service mode and following the prompts displayed. Follow the instructions exactly as displayed to safeguard against calibration errors:

1. Ensure that the Console is installed on the RenalGuard Cart pole with the weight scale chains attached in accordance with section 4.2. The infusion and collection sets are not required for this process.
2. Turn off the Console then turn it on again.
3. When the Same Patient/New Patient Screen is displayed, touch the upper right corner of the display three times. The Service Screen will be displayed.
4. Touch the **Weight Calibration** button.
5. Carefully follow the step by step instructions displayed on the touchscreen. The weight calibration will be performed by the system as the weights are placed and removed in response to the instructions displayed.
  - Place and remove the weights carefully to minimize any swaying of the chains.
  - Failure to follow the instructions as displayed may cause a Calibration Error message to be displayed.
  - Reset the Console and restart the weight calibration if a calibration error message is displayed. Turn the Console power off and then back on to reset the Console.
  - A message to save the settings will be displayed when the weight calibration is successfully completed.
6. Touch the **Save** button to record the calibration results. The display will return to the Service Screen.
7. Turn the Console off and then back on again to exit the Service mode.

The RenalGuard Console is now calibrated and ready for normal use. Record the date of the calibration.

## 2.9 Placement Requirements

The RenalGuard Console must be installed on the RenalGuard Cart pole.

The Console should be placed on the pole so that:

- The urine collection bag will be attached to the chain such that it hangs freely within the rectangular urine bag holder.
- The urine collection bag will be below the level of the patient's bladder to facilitate urine drainage.
- The urine and hydration fluid bags will hang freely from the hooks and be neither obstructed nor impeded by the bag holders, urine bag chain guide or other obstacles.
- The chain supporting the urine collection bag will pass through the ring of the chain guide clamp to minimize excessive swinging of the bag.
- Neither the infusion nor the collection tubing is kinked or pinched; nor are they pulling or straining the weight measuring devices.
- The RG console is positioned in the treatment area so that the power cord can be easily removed from its receptacle on the back of the RG console should the need arise.
- No other electrical equipment can be stacked on the RG console or cart.

**Caution:** *Installing the RenalGuard Console on an IV pole, particularly one that allows the upper portion of the pole to rotate separately from the lower half of the pole can interfere with the Console's ability to measure urine volume.*

**Warning:** *The RenalGuard Infusion Set can only be used with the RenalGuard console. It cannot be used with any other device or as a stand alone infusion set.*

## 2.10 Cleaning

The following cleaning procedures should be performed following each patient treatment with the RenalGuard System, or as required during treatment.

**Caution:** Exercise care during cleaning to ensure that liquids do not enter the Console. (The RenalGuard Console has been tested per IEC 60529 IPX2 to be resistant to vertically dripping fluids but is not liquid-tight.)

### 2.10.1 Cleaning the Touchscreen Display

Glass cleaner is recommended for cleaning the touchscreen. To reduce the risk of damage to the touchscreen, perform the following steps:

1. Do not apply glass cleaner directly to the touchscreen.
2. Moisten a clean lint-free cloth or paper towel with glass cleaner.
3. Use the moistened cloth or towel to gently clean the touchscreen.
4. Use a dry lint-free cloth or paper towel to remove any moisture remaining on the touchscreen.

### 2.10.2 Cleaning the Console and Cart Surfaces

RGS recommends Sani-Cloth Disinfecting Wipes Order No P22884 manufactured by Professional Disposables International Inc. located in Orangeburg New York

Conventional cleaners and disinfectants approved for general use by the facility may also be used for cleaning or disinfecting the Console and Cart.

Note: Using a stronger bleach solution than recommended for general use can cause damage or discoloration.

1. Clean spills from the surface of the Console and Cart using mild conventional cleaners.
2. Disinfect the surfaces of the Console and Cart using appropriate cleaning solutions.













Cleaning steps are listed below:

1. Turn the console off, ensure the single use set has been removed, and unplug the AC power adaptor from the power source.
2. Apply the compatible cleaning agent with disinfecting wipes or with a dampened cloth per the manufacturers' instructions using appropriate dilution ratio.
3. Apply the wipe or cloth to every exposed surface on the console, taking care to ensure that the air detector, pressure sensor receptacle, infusion chain, urine chain, pump, and vent on the top rear of the console are cleaned.

4. Apply the wipe or cloth to every exposed surface on the cart, taking care to ensure that the handle, infusion bag holder, urine bag holder, pole, chain guide, and the base are cleaned.
5. Dispose of all cleaning materials as required per facility protocol/biohazard policy

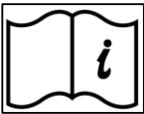
## 2.11 Symbols

The following symbols appear on the RenalGuard Console, the RenalGuard Single Use Set or the packaging.

Symbol	Description	Location	Reference
	“Attention!” Consult Operator’s Manual or written warnings	Console label	ISO 15223-1
IPX2	Ingress protection rating per IEC 60529 - enclosure is resistant to vertically falling water drops.	Console label	IEC 60529
	Defibrillator-proof Type CF equipment per IEC 60601-1 equipment is electrically isolated from the patient.	Console label	IEC 60601-1
	Do Not Dispose compliant with the Waste in Electrical and Electronic Equipment (WEEE) Directive 2012/19/EU	Console label	EN 50419
	Equipotentiality (identifies the equipotential ground stud located on the rear panel)	Console label	IEC 60601-1
	Serial Number	Console label	ISO 15223-1
	Fuse	Console label	
	Alternating current	Console label	IEC 60601-1
	RS-232 “For service use only”	Console label adjacent to the RS-232 port	n/a
	Consult Instructions for Use	Directions for Use Label	ISO 15223-1
	Instruction manual/booklet must be read.	Directions for Use Label	IEC 60601-1
	Catalog or Reference number	Console label and Single Use Set label	ISO 15223-1
	Date of Manufacturing	Console label and Single Use Set label	ISO 15223-1

Symbol	Description	Location	Reference
	Manufacturer	Console label and Single Use Set label	EN 980
	Lot number	Single Use Set label	ISO 15223-1
	Temperature limits to which the package can be subjected	Exterior of the shipping package	ISO 15223-1
	Battery charge symbol	Front panel adjacent to the battery charge indicator LED	ISO 15223-1
	On - enables Console operation	On/Off switch	IEC 60601-1
	Off - disables Console operation	On/Off switch	IEC 60601-1
	Use By (expiration date)	Single Use Set label	ISO 15223-1
	Sterilization using ethylene oxide	Single Use Set label	ISO 15223-1
	Do Not Re-sterilize (Reuse may result in infection)	Single Use Set label	ISO 15223-1
	Do not use if package is damaged	Single Use Set label	ISO 15223-1
	Humidity limit to which the package can be subjected	Single Use Set label	ISO 15223-1
	Authorized representative in the European Community	Single Use Set label	EN 980
	Latex free	Single Use Set label	ISO 15223-1
	Non-pyrogenic	Single Use Set label	ISO 15223-1

## 2.12 Label Images

Label Image	Description and Location
	<p>System Label (located on the rear panel of the Console)</p>
	<p>Grounding Reliability Warning Label (located adjacent to the power inlet/cord receptacle on the rear panel of the Console)</p>
	<p>Fluid Flow Label (located adjacent to the pump head on the front of the Console)</p>
	<p>Loading Guide Labels (1), (2), (3) &amp; (4) (located along the tubing path on the front of the Console)</p>
	<p>ETL Listed Label (located on the underside of the Console)</p>
	<p>Investigational Device Label * (located in the front of the Console) * USA units only</p>

**Label Image**

**Description and Location**

Use only RenalGuard® Single Use Sets.

**To Initiate Therapy:**

- Attach the RenalGuard Single Use Set to the Console according to the set's DFU
- Turn the Console on
- When asked, press **Begin New Patient**
- Press **Start Prime** to begin Prime
- When Prime has completed, inspect circuit for leaks or air bubbles
- Attach the RenalGuard Single Use Set to the patient according to the set's DFU
- Press **Run** to begin therapy

**To Adjust Settings**

- Press **Settings**. Select the menu containing the setting you would like to change.
- Press the desired setting you would like to change
- Use arrows (▲▼) to change the setting
- Press **Save Setting** to store the setting

**To Empty Urine Bag**



- Press **Pause** button to enter Pause mode
- Open clamp to drain urine collection bag
- When draining is complete, ensure drain clamp is closed
- Press **Run** to re-start therapy.

**To Change Infusion Bag**

- Press **Stop** to enter Stop mode
- Replace infusion bag
- Press **Run** to re-start therapy

**Handling Alerts or Alarms**

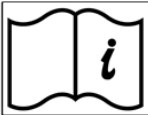
- Press **Silence** to silence the tone
- To reset an alert, Press **Clear Alert**
- If in Pause mode, correct the alert cause, then press **Run** to resume therapy
- To reset an alarm, Press **Clear Alarm**
- After correcting the alarm cause, press **Run** to resume therapy

La00256 Rev E

Directions for Use Label  
(located in the left side of  
the Console enclosure)

**CardioRenal Systems, Inc. CE**  
0044

459 Fortune Blvd.  
Milford, MA 01757

**LITHIUM BATTERY INSIDE**  
Do not damage or mishandle this package

Manufacturer's Representative  
in the European Union  
PLC Systemas Medicos Internacionais  
Borsteler Chaussee 55  
22453 Hamburg Germany EC REP

85% RH 45°C  
20% RH -10°C

**RenalGuard®**

REF FM1  
SN 6409  
2017-12-20

Made in USA Pat. RenalGuard.com p/n La00248 Rev L

(01) 0 0866379 00012 2 (11)20171220(21)6409

Outer Package Label  
(located on the outside of the shipping  
container)

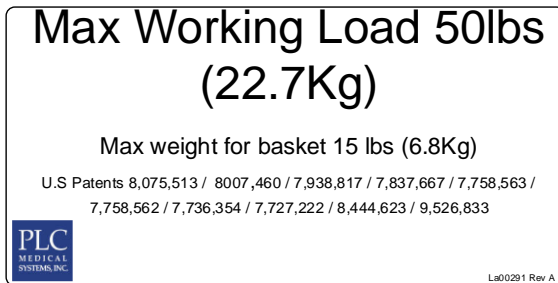

RenalGuard Logo  
(located in the front of the Console)

**Label Image****Description and Location**

RenalGuard Cart label  
(located on basket of RenalGuard Cart)

## 2.13 Abbreviations

cm	centimeter
Hz	Hertz
IV	intravenous
Kg	kilogram
KVO	Keep Vein Open
LED	Light Emitting Diode
ml	milliliters
ml/hr.	milliliters per hour
psi	pounds per square inch
VAC	Volts Alternating Current

## 2.14 Service Information

For technical assistance, contact the address below:

**Internationally:**

PLC Systemas Medicos Internacionais  
(Deutschland) GmbH  
Borsteler Chaussee 55  
22453 Hamburg  
Tel: +49 40 450322 0  
Fax: +49 40 450322 1

**United States:**

RenalGuard Solutions, Inc.  
459 Fortune Blvd  
Milford, MA 01757  
Phone: + 1-508-541-8800  
Fax: + 1-508-541-6768

RGS will supply service documentation if requested. However, we strongly recommend you attend a factory training class before attempting any RG Console repairs.

## **2.15 Disposal of Waste Electrical and Electronic Equipment**

To comply with European Commission Directive 2012/19/EU on Waste Electrical and Electronic Equipment (WEEE) and other country and state regulations, please do not dispose of this equipment in any location other than designated locations. Contact RenalGuard Solutions Customer Service or your local RenalGuard dealer for proper product disposal.

## 3. Device Description

### 3.1 Theory of Operation

The RenalGuard System maintains the hydration balance by measuring patient urine output and infusing hydration fluid (prescribed by physician) into the patient IV to balance the fluid lost in urine.

In addition to urine volume replacement, RenalGuard implements user-set Bolus, Percent Match, and Desired Fluid Balance. Bolus is defined as the amount of fluid in ml infused into IV in addition to the replaced volume of urine over a 30 minute period. The Percent Match setting adjusts the urine volume replacement from the default 100 % replacement to the user defined replacement ratio. This match is set as a percentage of the urine volume measured, with a range of 0% to 100 %. The Desired Fluid Balance Setting allows the user to adjust the goal of the RenalGuard System to achieve the desired fluid balance, which can be either positive or negative. Additionally, the Other Intake Rate allows the user to instruct the RenalGuard Console to take into account other fluid inputs when attempting to reach the set Fluid Balance or Percent Match goal.

The RenalGuard System is comprised of a Console, a Cart and a RenalGuard Single Use Set for infusion and urine collection. The Console is a microcontroller-based device that has a means for measuring urine and the ability to infuse hydration fluid into the patient. The rate of infusion of hydration fluid is controlled by the Console based on measured urine volume and user settings.

The Console is equipped with an internal battery that can sustain operation in the event of power outage or during short periods of time, when the patient is moved. The RenalGuard Console is to always be plugged into the AC outlet for operation and battery charging.

The Cart provides the mounting platform for the RenalGuard Console. The cart has a pole and a base with 5 wheels, 2 of them locking to restrict movement, if necessary. The cart includes containment housings for the infusion and urine collection bags.

### 3.2 RenalGuard System Overview

The RenalGuard System consists of the microcontroller-based Console, a Cart and a RenalGuard Single Use Set that is connected to the Console for therapy. The Console is mounted on the Cart.

The Console includes a roller pump, a user interface, two weighing scales, an air detector, a post-pump pressure sensor, an electrical connector for AC power, and mechanical interfaces for holding the Set in place. The Console controls the rate at which fluid is infused and monitors urine volume by weight measurement.

To initiate treatment, the RenalGuard System requires: a) peripheral IV access, b) a urinary Foley catheter and c) an appropriate number of one liter bags of the physician prescribed hydration fluid.

Priming of the RenalGuard Single Use Set is initiated by the user prior to treatment. During operation, the user is responsible for a) draining the urine bag when full, b) replacing hydration fluid bags when empty, and c) responding to alarms and alerts issued by the Console.

### 3.3 System Display

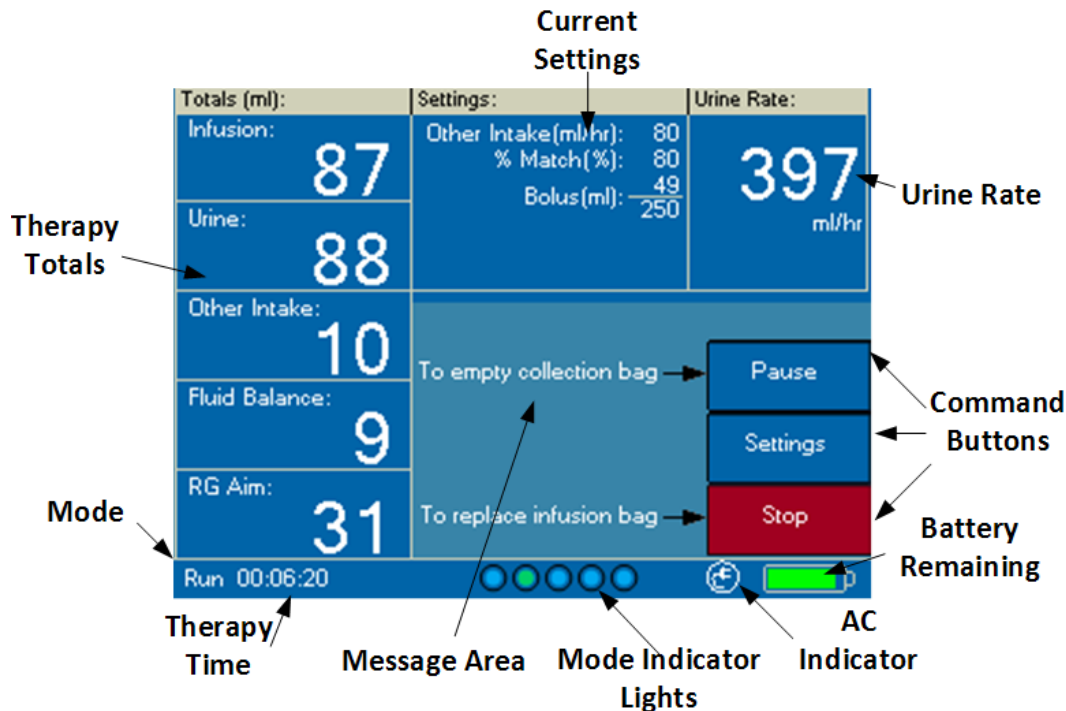

Explanation of RenalGuard Console System Display:

**Urine Rate:** Urine rate based on recent urine output.

**Current Settings (see section 4.7 for more information on settings):**

**Bolus (ml):** The top number indicates the current bolus target added to the infusion goal (see RG Aim below). The second number indicates the total amount of bolus to be infused based on user settings. Only displayed if Bolus is set and currently being infused.

**Other Intake (ml/hr):** User set rate of fluids from other sources that the patient is receiving. Only displayed if value is not 0.

**Desired Fluid Balance (ml/hr):** User set desired hourly fluid balance. Only displayed if value is not 0.

**Percent Match (%):** User set percent of the urine output that should be matched by hydration fluid. Only displayed if set value is not 100%.

**Total Information (all units in ml):**

**Infusion:** Total fluid infused since the start of the therapy. This includes fluid infused for Urine Volume replacement and fluid infused in response to all user settings.

**Urine:** Total urine collected since the start of the therapy.

**Other intake:** Total of the other fluids in ml that the patient has received since the start of therapy based on the user set "Other Intake" rate

**Fluid Balance:** Total Fluid Balance since the start of the therapy in ml. This is calculated using the formula:

$$\text{Total Fluid Balance (ml)} = \text{Total Infused (ml)} + \text{Total Other Intake (ml)} - \text{Total Urine (ml)}$$

**RG Aim:** Current target total fluid balance in ml which is calculated based on urine output and user settings, including Bolus, Percent Match, and Desired Fluid Balance.



**Mode:** Indicates the current mode of the RenalGuard Console (Run, Stop, Advance, or Pause, see sections 4.4 through 4.14 for more information).

**Therapy time:** This indicates the total time that the RenalGuard Console has been in Run mode since the start of the current therapy.

**Message Area:** This area is used to display user messages, alerts, and settings screens.

**Mode indicator lights:** The mode indicator lights provide a means to determine the mode of the RenalGuard Console even when the user is too far away to read the mode:

- Run mode: a green light will rotate through the indicator lights.
- Pause mode: all five indicator lights will flash orange.
- Stop mode: all five indicator lights are off.
- Advance mode: a green light will rotate through the indicator lights.

**AC indicator:** The symbol  indicates that the Console is connected to an AC supply. The symbol  indicates that Console is not connected to an AC supply.

If the Console is connected to an AC supply and the indicator is displaying the symbol , confirm that the Mains AC switch located on the rear panel is in the On (|) position.

**Battery remaining:** Approximate battery charge remaining. Displays orange bar when less than 30 minutes of battery charge remain.

**Command Buttons:** Used to operate the RenalGuard Console. Section 4 explains all of the command buttons in greater detail.

## 3.4 User Settings

The RenalGuard Console allows the user to enter following parameters:

1. Minimum hydration rate in ml/hr
2. Desired Fluid Balance in ml/hr

3. Bolus Amount in ml
4. Percent Fluid to be Matched in %
5. Other Fluids being infused by external sources that need to be taken into account in ml/hr
6. Maximum allowed accumulated Positive Fluid Balance and minimum allowed Negative Fluid Balance for alert only
7. Minimum urine output in ml/hr for alert only

Refer to section 4.7 for additional information of the user settings.

### **3.5 Safety Features**

The RenalGuard System includes the following features designed to protect the patient from potentially hazardous conditions. The operating system detects malfunctions and alarms the user as needed.

1. Air detector with automatic infusion pump shut-off
2. Post-pump downstream pressure sensor to detect occlusions
3. Pump motor speed monitoring by optical encoder
4. Weight scale monitoring of infusion fluid to detect leaks and pre-pump upstream occlusions
5. Weight scale monitoring of urine volume to detect leaks and urine Collection Set occlusions
6. Free flow protection device (pressure valve)
7. Pump door open detector with automatic motor shut off

## 3.6 Audio Indicators

The RenalGuard Console uses different audio indicators to alert and inform the user of the status of the Console.

1. A series of 10 beeps repeated every 15 seconds indicates a High priority alarm condition. Refer to section 5.0 for more information
2. 1 beep repeated every 15 seconds indicates a Low priority alert condition. Refer to section 5.0 for more information
3. A low-volume beep while the Console is in Stop or Pause mode indicates to the user that the Console is not in Run mode.
4. A high-volume beep while the Console is in Stop or Pause mode indicates to the user that the Console has not been in Run mode for more than 15 minutes. The tone will not stop until the user enters Run or Advance mode.

## 4 Operation

### 4.1 Features

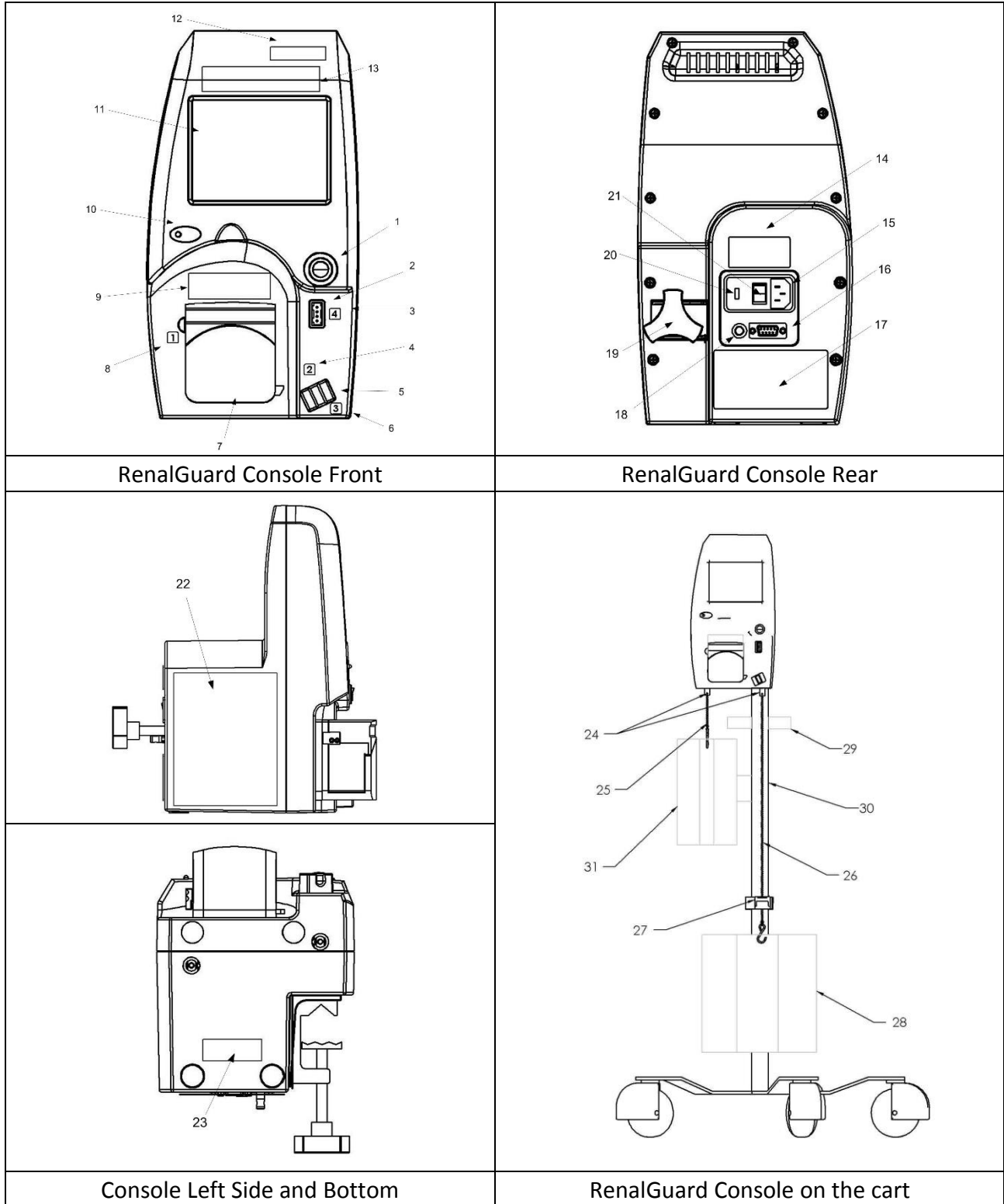

#	Description	Function
1.	On/Off Switch	Turns the RenalGuard Console On or Off
2.	Pressure Sensor	Detects occlusions in the IV line.
3.	Loading Guide Label (4)	Location for the RenalGuard Single Use Set pressure sensor connection
4.	Loading Guide Label (2)	Location for the corresponding marker on the RenalGuard Single Use Set
5.	Bubble Detector	Monitors air bubbles passing through the RenalGuard Single Use Set
6.	Loading Guide Label (3)	Location for the corresponding marker on the RenalGuard Single Use Set
7.	Pumping Mechanism	Peristaltic pumping mechanism
8.	Loading Guide Label (1)	Location for the corresponding marker on the RenalGuard Single Use Set
9.	Fluid Flow Label	Indicates the direction of fluid flow through pump
10.	Battery LED	Constant yellow - indicates that the internal battery is charging
11.	Touch Screen Display	Performs all user interface functions of the RenalGuard Console
12.	Investigational Device	Identifies the RenalGuard Console as a US FDA investigational device *
13.	RenalGuard Logo	Identifies the RenalGuard Console
14.	Grounding Label	Informs the user to use only a hospital grade grounded outlet
15.	Power Entry Module	Includes the cord receptacle, the mains fuses and the mains on/off switch
16.	Serial Port	External communication port (For Service Use Only)
17.	Product Label	Includes Manufacturer, Model, and Serial # information
18.	Ground Equalization Stud	Provides the ability to ground external equipment through the system ground
19.	Pole Clamp	Clamps the Console to the Cart pole
20.	Mains Fuses	Replaceable fuses Type T5AH250V (the module back opens for fuse access)
21.	Mains switch	Switches the AC mains power On or Off.
22.	Directions for Use Label	Directions for Use
23.	ETL Listed Label	Identifies the ETL certification information
24.	Chain Guide Tubes	Protects the load cells (weight scales) from damage (only with Consoles that do not have attached chains)
25.	IV Chain Assembly	Hangs the IV Bag for monitoring by the load cell
26.	Urine Chain Assembly	Hangs the Urine Bag for monitoring by the load cell
27.	Chain Guide Assembly	Controls motion of urine bag during transit
28.	Urine Bag Holder	Restricts urine bag movement during transit
29.	Handle	For use during transit
30.	Pole	For mounting Console
31.	Infusion Bag Holder	Restricts infusion bag movement during transit

•USA units only

## 4.2 Installation and Setup

This section describes the initial installation procedure for the RenalGuard System.

### 4.2.1 Console Unpacking and Initial Inspection

When unpacking the RenalGuard System Console, follow these steps:

1. Inspect each container at the time of delivery for signs of damage or any indication of improper handling during shipment.
2. Ensure that the following components are included:
  - RenalGuard Console
  - Infusion chain with hook
  - Urine chain with hook
  - 2 chain guide tubes (only with Consoles that do not have attached chains)
  - AC power cord
  - This operator's manual
3. The RenalGuard Cart is packaged in a separate shipping box.
4. Immediately document and report any shipping damage or missing accessories to both the carrier and to an authorized RenalGuard Solutions representative. Failure to do so invalidates the warranty.

## 4.2.2 Cart Unpacking, Inspection and Assembly

The RenalGuard cart is shipped in a separate container. Assembly in accordance with the instructions below is required. RenalGuard cart is now shipped almost fully assembled. Unpack the RG cart components and inspect them against the exploded drawing to confirm the presence of all the parts. A Phillips screwdriver (not provided) will also be required.

Parts and Tools included:

- Wheel Base (20) with wheels (17 & 18) attached,
  - Bottom Post (1) with Basket (5) and Rectangular Bag Holder (7) attached. (Hardware (2, 3 and 19) connected at bottom of pole.
  - Top Post (4) with Handle (14) and Round Bag Holder (6) attached
  - Chain Guide (8) with Tube Holder (9) attached. (Hardware (16) connected to chain guide. Cap (13) in bag containing chain guide)
  - Two Allen wrenches (not shown)
1. Locate the notch in center hub of the 5-star wheel base (20). Casters are already attached to base.

2. Remove hardware (2,3 & 19) from bottom of bottom post (1). Align the roll pin at the base of the bottom post (1) with the notch (detail A) in the hub of the 5-star wheel base. Insert the post into the hub.
3. Stack the flat washer (19), lock washer (3) and the 3/8-16 x 1 1/4" screw (2) as shown. Using the larger Allen wrench, securely fasten the post to the base.
4. Install top post (4) into bottom post. Posts will only connect in one orientation (See Detail B) (1) Insert one 10-32 x 1" (16) Philips screw through the mounting hole in the post, to secure the chain guide (8) to the post, and insert plug (13).
5. The handle may be re-positioned as needed (using the smaller of the two Allen wrenches) when the Console is placed on the stand.

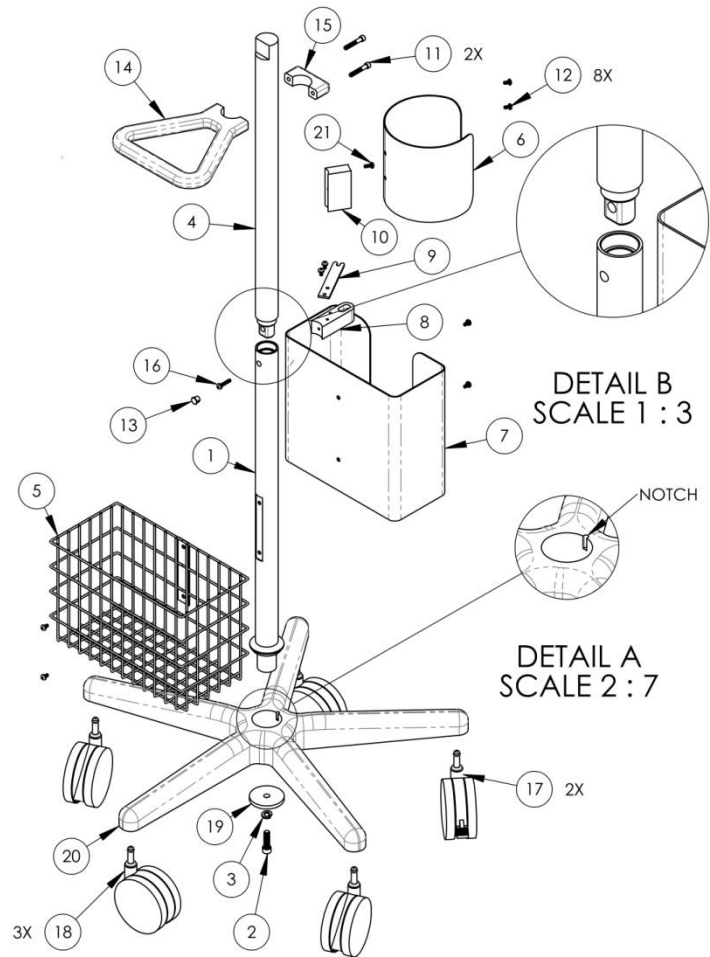

## 4.2.3 Initial Setup

This section details the initial setup of the RenalGuard System. The Console mounts to the assembled Cart.

To setup the RenalGuard System:

1. Remove the Console from its packaging.
2. Attach the Console to the pole of the assembled cart using the black clamp on the back of the Console.
3. If the weight scale chains are not attached when you unpack the Console, follow the step 3a instructions, otherwise proceed to step 4.
4. The chain guide clamp prevents the long urine chain from moving excessively.
  - a. Pass the long urine chain through the opening of the hole in the chain guide.
  - b. Ensure the urine bag is hanging freely.
5. Connect the medical grade AC power cord to the power entry module located at the rear of the Console. Plug the power cord into an outlet labeled 'Hospital Only' or 'Hospital Grade' to ensure grounding reliability. (Refer to section 2.6 for detailed electrical requirements).
6. Ensure that the **Mains** power switch located on the power entry module on the back of the Console is in the On (|) position. If this switch is Off, AC power will not be connected, even if the Console is plugged in, and the Console will run on battery power.
7. Set the **On/Off** switch on the front of the Console to the On position (|) to power up the Console and start the internal self-test. The Console will emit a short tone indicating that the diagnostic self-test has started. The message: Performing self test will be displayed. The self-test takes approximately 20 seconds. Once the self-test has completed, the

3a For systems that do not have attached chains:

Attach the weight scale chains to the Console (refer to the image of the RenalGuard Console attached to the Cart Pole in section 4.1):

- a. Slide a chain guide tube over the short Infusion chain, ensuring that the threads on the chain guide tube are facing away from the hook.
- b. Facing the Console, screw the threaded end of the short Infusion chain into the left hole underneath the Console. Using a clockwise motion, continue until the chain is snug, but do not over tighten.
- c. Screw the chain guide tube into the hole using a clockwise motion.
- d. Slide the other chain guide tube over the long Urine chain, ensuring that the threads on the chain guide tube are facing away from the hook.
- e. Facing the Console, screw the threaded end of the long chain assembly into the right hole underneath the Console. Using a clockwise motion, continue until the chain is snug, but do not over tighten.
- f. Screw the chain guide tube into the hole using a clockwise motion. Proceed to step 4.

**Continue with Same Patient** and the **Begin New Patient** buttons will be displayed. This indicates that the self-test has completed successfully.

- If the self-test fails, the Console will emit an audible alarm and display an error message. Set the **On/Off** switch to the Off position (O). Wait 5 seconds and then reset the **On/Off** switch to the On position (I). If the error reoccurs, remove the system from use and contact service.

#### 4.2.4 Powering Down and Storage

Set the front panel **On/Off** switch to the Off (O) position to power down the Console.

- Console may be stored on the RenalGuard Cart., or
- Console can be removed from the RenalGuard Cart. and stored on a flat surface.

The AC power cord should remain plugged in whenever the Console is in storage to ensure that the internal batteries remain charged.

#### 4.2.5 Charging the Battery

Keeping the battery fully charged prevents unnecessary low battery alerts during operation. The system will operate on a fully charged battery for at least 30 minutes; however, it is advisable to recharge the battery whenever the battery remaining time shown in the battery icon on the bottom right corner of the display is less than half charged.

The remaining battery operation time is shown in the lower right corner of the display.

- To begin charging the battery, connect the Console to an appropriate AC outlet. Insure that the **Mains** switch located on the rear panel is in the On (I) position. The yellow battery LED on the control panel will remain illuminated while the battery is being charged.
- The Console will enter a 2 hour battery charge period after it is plugged in. The yellow LED will turn off when charging stops.
- The battery charging period may end before the battery is fully charged. The battery remaining time is displayed on the bottom right corner of the display. If the Console displays a less than half charge remaining, restart battery charging to fully charge the battery.
- To restart battery charging, insure that the Console is connected to an appropriate AC outlet. Turn the **Mains** switch located on the rear panel to the Off (O) position and then back to the On (I) position. The yellow LED will illuminate to indicate that battery charging has resumed.
- Depending upon the initial battery condition, it may be necessary to restart battery charging several times to fully charge the battery.

## 4.3 Therapy Setup

**Caution:** The RenalGuard Console should be plugged in at all times. Failure to do so may result in decreased battery operation time.

1. Connect the medical grade power cord to the power entry module located at the rear of the Console. Plug the cord into an outlet labeled 'Hospital Only' or 'Hospital Grade' to ensure grounding reliability. Ensure that the mains power switch located on the power entry module on the back of the Console is in the On (up) position.



2. Set the **On/Off** switch on the front of the Console to On. The Console will emit a short tone indicating that the diagnostic self-test has started. The message: **Performing self test ...** will be displayed. The self-test takes approximately 20 seconds. If the self-test fails, the Console will emit an audible alarm and display an error message. Set the **On/Off** switch to Off. Wait 5 seconds and then reset the **On/Off** switch to On. If the error reoccurs, remove the system from use and contact service.

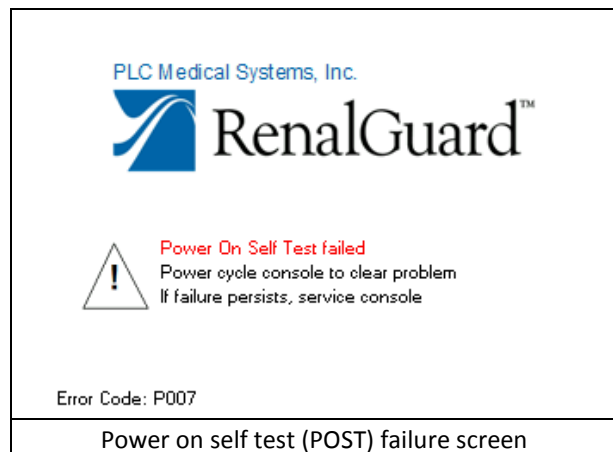

3. The Console will display the Same Patient/New Patient screen:

a. Pressing the **Continue with Same Patient** button restores all previous information used for therapy before the power was turned off, including all settings, *Bolus Administration, Target Balance Value (RG Aim), Elapsed Time, Other Fluid Intake, Urine Measured, and Fluid Infused.*

b. Pressing the **Begin New Patient** button indicates that therapy on a new patient is to be started. All settings and therapy parameters are restored to zero or to the system defaults. If the **Begin New Patient** button is pressed accidentally, press the **Back** button to return to the patient selection screen.



## 4.4 Loading the Infusion Set

1. Visually examine the RenalGuard Single Use Set to determine that the package has not been opened or damaged during shipping. Once opened, preserve sterility.
2. Open the pump door and load the pump segment tubing over the rollers. Line up the loading guide markers (1) and (2) on the Infusion Set with the loading guide labels (1) and (2) on the Console. Assure that the clips on ends of the raceway are lined up with the tube segment. Close the pump door firmly until you hear a click. Check that the tubing is aligned correctly. Ensure that the tubing from the infusion bag side enters on the left side of the pump.
3. Line up the loading guide marker (3) on the Infusion Set with the loading guide label (3) below the air detector on the front of the Console. Insert tubing into air detector channel, ensuring that the tubing is firmly seated.
4. Plug the transducer connector marked (4) on the Infusion Set into the pressure transducer receptacle (labeled (4)) on the front of the Console. Ensure that the connector is fully seated.

**Caution:** *The RenalGuard System is designed for use with 1 (one) liter infusion bags only. The System will not operate properly with other sized infusion bags.*

5. Using the standard technique, spike a 1 liter infusion bag using the Infusion Set bag spike.
6. Facing the front of the Console, hang the full infusion bag on the Left chain hook. Ensure that the bag hangs freely and that its motion will remain unobstructed as it empties.

7. Facing the front of the Console, hang the empty Collection Set urine bag on the Right chain hook. To minimize excessive swinging of the urine collection bag, ensure that the chain supporting the bag passes through the ring of the chain guide assembly. Ensure that the bag hangs freely and that its motion will remain unobstructed as it fills.
8. Insert the collection set tubing into the notched hose holder on the chain guide assembly. Align the Yellow loading guides on the tubing to the right and left of the notch to prevent the tubing from pulling on the urine collection bag.
9. Confirm that the drain valve at the bottom of the urine collection bag is fully closed.

**Warning:** *The RenalGuard System will not operate properly if the urine bag is not hanging freely on the weight scale chain, or is interfered with in any way.*

## 4.5 Priming the RenalGuard Single Use Set

**Caution:** *It is necessary to complete the priming procedure before connecting the patient for therapy. The RenalGuard Console performs required safety checks during the priming procedure.*

**Warning:** *Do not connect the patient to the Infusion Set during the priming procedure. The air detector is disabled during priming. This could result in air being introduced into the patient.*

**Caution:** *The RenalGuard Single Use Set can only be primed using the following automatic priming procedure. The set cannot be primed by gravity flow.*

1. Use the Luer - to - Foley adapter to connect the end of the Infusion Set tubing to the end of the urine Collection Set tubing. The adapter is intended for priming only and is not to be used during patient therapy.
2. Support the tubing to ensure that tension is not exerted on either the hydration or collection bags or on their suspension chains. The Cart pole may be used to provide support.
3. Ensure that the clamp on the Infusion Set is open.

4. Once the RenalGuard Single Use Set is correctly installed, press the **Start Prime** button.

5. During Prime mode, inspect the Infusion Set for any leaks. If necessary, gently tap on the tubing and/or squeeze the drip chamber to release any air bubbles.

6. Prime mode will run the pump for approximately 2 minutes, and will stop automatically. Approximately 150 ml of fluid will be pumped from the hydration bag into the urine collection bag during Prime.

- Do not touch the infusion bag or urine bag during Prime. The weight scales monitor both the infusion and collection bags weights during Prime to confirm that the RenalGuard Single Use Set has been installed correctly.
- If the Prime procedure fails, the Console will emit an audible alarm and display an error message. Press the **Silence** button to silence the alarm then follow these steps:

- a. Check the connections to the priming adapter and confirm that they are tight. Loose connections can cause leaks, resulting in Prime failures.
- b. Confirm that the set is installed correctly (i.e. bag obstruction, tubing leaks, inadequate connections, tube not in air detector, etc.). Once the visual check is complete, press the **Clear Alarm** button and repeat step 4.

- c. If the Prime procedure fails 3 or more times, discontinue use of the RenalGuard Single Use Set. It may be necessary to replace the RenalGuard Single Use Set or the RenalGuard Console. Contact your service representative (refer to section 2.14 Service Information).

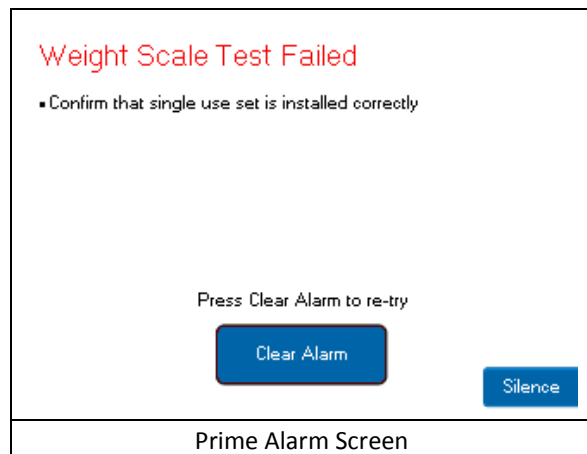
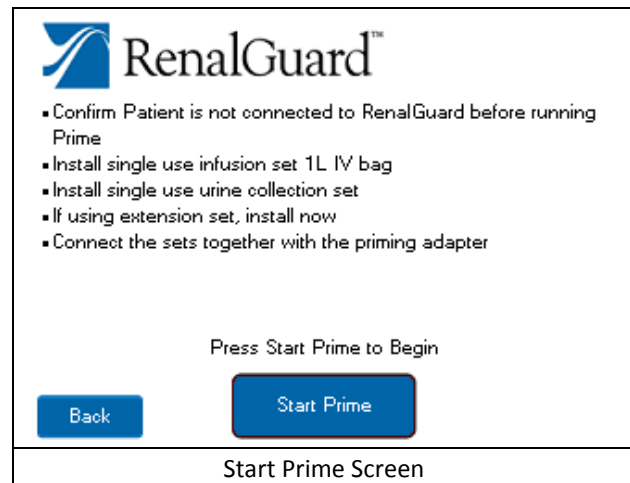

7. Prime mode may be discontinued at any time by pressing the **Stop Prime** button. To restart, press the **Start Prime** button. Priming will restart from the beginning.

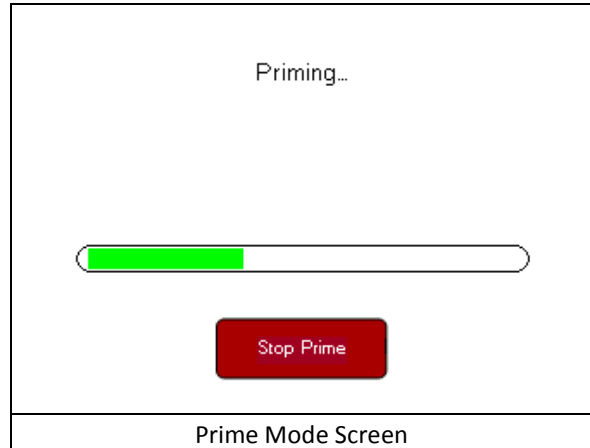

8. When the Prime procedure ends and the pump stops, carefully examine the entire Infusion Set to ensure that it is fully primed and that no air is present in the infusion tubing.
9. If air remains in the infusion tubing after Prime, use the **Advance** button to remove.

- d. Press and hold the **Advance** button to run the pump. Once the **Advance** button is released, the pump will stop within 2 seconds.

- e. The pump will automatically stop when the **Advance** button has been depressed for 30 seconds. It will be necessary to release and then re-press the **Advance** button to run the pump for as long as an additional 30 seconds.

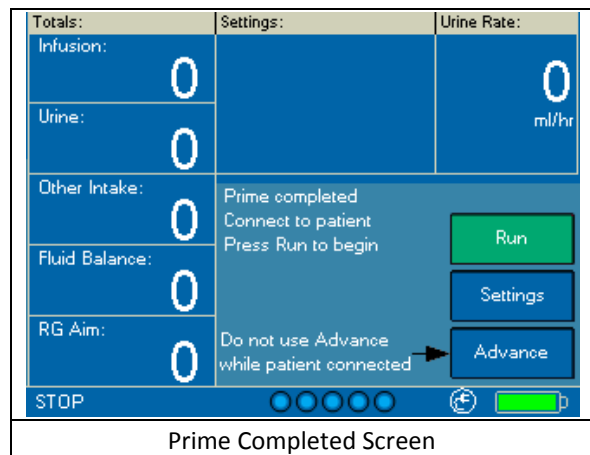

**Warning:** Air detection is disabled during **Advance** button operation. The **Advance** button must not be pressed while the Infusion Set is connected to the patient.

10. When the Console has determined that Prime has been successfully completed, the message: "Prime completed. Press **Run** to begin", will be displayed.

## 4.6 Connecting the RenalGuard System to the Patient

**Warning:** *Aseptic technique must be used throughout the procedure. Usual and customary hospital infection control practices should be followed when replacing the patient connected tubing to ensure the safety of the patient and clinician.*

1. Ensure that both the Urinary Catheter and the IV Catheter have been successfully inserted into the patient and are prepared for use. The Urinary Catheter and IV Catheter should be flushed and flowing properly prior to connecting the RenalGuard Single Use Set.
2. Disconnect the Luer connector of the Infusion Set from the prime adapter. Remove the prime adapter which is only used during the priming procedure. The adapter should be discarded at this time. The priming adapter is not intended to be connected to the patient.
3. Connect the Luer connector of the Infusion Set to the inserted IV catheter. Ensure that no air enters the system. Turn the Luer connector until it is completely closed. Do not over tighten.

**Warning:** *Automatic air detection is disabled during manual connection operations.*

4. Visually check for air in the Infusion Set.
  - If air is noted, disconnect the Infusion Set from the inserted IV catheter and use the Advance mode to purge the air.
  - Press and hold the **Advance** button to run the pump. Once the **Advance** button is released, the pump will stop within 2 seconds.
  - The pump will automatically stop when the **Advance** button has been depressed for 30 seconds. It will be necessary to release and then re-press the **Advance** button to run the pump for as long as an additional 30 seconds.
5. Connect the male Foley connector of the Collection Set to the inserted urinary catheter.

**Warning:** *The urine collection bag must be below the level of the patient's bladder to facilitate urine drainage.*

## 4.7 Setting and Changing Parameters

The RenalGuard Console has 4 user settings menus :

- Infusion Settings,
- Fluid Balance Settings,
- Percent Match Settings, and
- Alert Limit Settings.

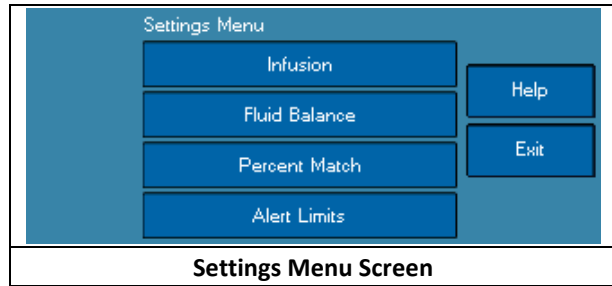

- If a setting change is desired, press the **Settings** button from the main screen. The Settings Menu Screen will be displayed.
- Press the button for the desired settings menu and it will be displayed.
- Touch the **Help** button to display short explanations of each of the available settings

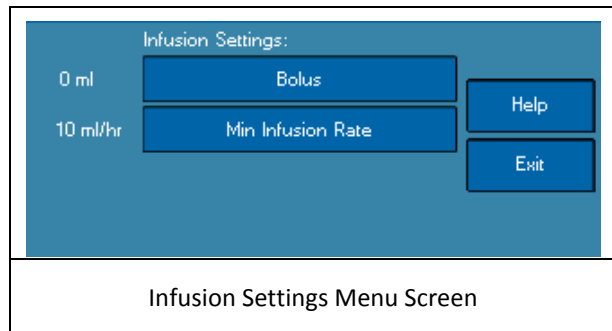

- Press the button for the setting to be changed. An adjustment screen similar to the one to the right will be displayed: Use the **Up and Down Arrow** buttons to adjust the setting.
- Press the **Save Settings** button to confirm the new setting. If the **Save Settings** button is not pressed, the previously stored setting will be used.

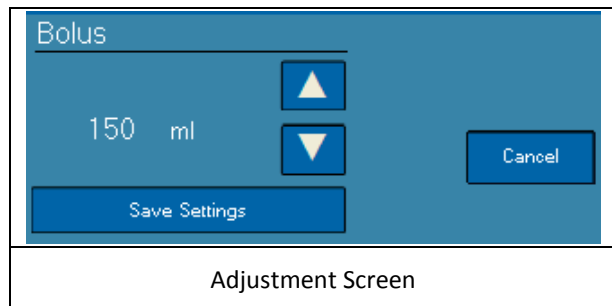

**Warning:** The RenalGuard System does not measure the total volume removed from or infused into the patient. The System only measures the urine output and system hydration rate. It is the user's responsibility monitor the patient's overall hydration status. If other fluids are infused or removed, the user is responsible for keeping track of the total amount of fluid infused or given orally and adjusting patient settings accordingly.

## 4.7.1 Infusion Menu

### 4.7.1.1 Bolus Deliver Setting

**Units:** milliliters

**Range:** 0 to 500 ml

**Default:** 0 ml

This setting allows the user to infuse additional fluid into the patient's IV when clinically indicated. Any volume set for the Bolus will be delivered over a 30 minute period.

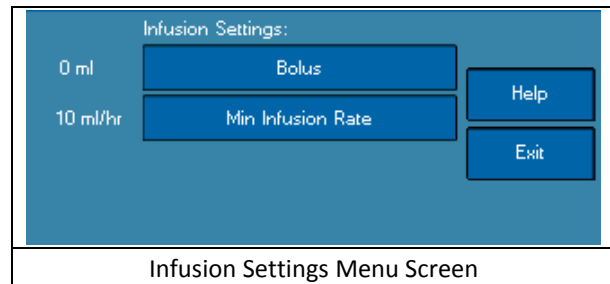

- The Bolus Volume is infused in addition to the Fluid Balance Setting and the Urine Volume replacement amounts.
- If the Bolus delivery is interrupted by the Console entering Stop or Pause mode, Bolus delivery will automatically resume and complete as soon as the System is returned to normal operation.
- If the desired Bolus delivery amount is changed prior to completing the 30-minute period, the new bolus amount will be delivered over the remaining 30 minutes. If the new bolus amount is less than the amount of bolus already delivered the bolus input for the remaining 30 minute period will be zero

### 4.7.1.2 Minimum Hydration Rate Setting

**Units:** milliliters / hour

**Range:** 10 to 100 ml/hr

**Default:** 10 ml/hr

This setting establishes a minimum pump rate during Run and Pause mode. Regardless of the urine rate and other fluid balancing settings, the infusion pump will infuse hydration fluid at the set Minimum Hydration Rate. In Pause mode the infusion pump only runs at the Minimum Hydration Rate.

**Warning:** Both of these settings can cause the RenalGuard System to infuse fluid over and above the patient's urine output volume. It is the user's responsibility to confirm that this is an appropriate fluid balance for the patient.

## 4.7.2 Fluid Balance Menu

### 4.7.2.1 Desired Fluid Balance Setting

**Units:** milliliters / hour

**Range:** -1000 to 500 ml/hr

**Default:** 0 ml/hr (balance)

The Desired Fluid Balance, in ml / hr, is the desired hourly fluid balance that the RenalGuard System attempts to achieve by adjusting the infusion pump. The Console takes the patient's urine output and the Other Fluid Intake setting into account when trying to achieve the Desired Fluid Balance. This setting can be positive or negative. If positive, the System attempts to balance the measured urine output and infuse the set rate of fluid over and above the match. If negative, the System attempts to replace the set rate less than the measured urine output. If the urine rate is too low to allow the System to reach the negative Desired Fluid Balance, the pump runs at the minimum hydration rate. Touching the Default Fluid Balance button will reset the setting to the default value.

**Caution:** This setting will cause the RenalGuard Console to infuse fluid either above or below the patient's urine output volume. It is the user's responsibility to confirm that this is an appropriate fluid balance for the patient.

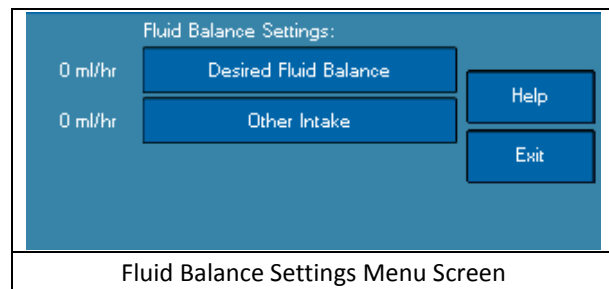

### 4.7.2.2 Other Fluid Intake Setting

**Units:** milliliters / hour

**Range:** 0 to 2000 ml/hr

**Default:** 0 ml/hr

The Other Fluid Intake setting allows the user to inform the RenalGuard Console of the rate of other fluid intake into the patient. The Console then takes this setting into account when attempting to achieve the Desired Fluid Balance setting.

**Caution:** This setting relies on the user input to calculate the total volume of fluid intake from other sources. It is the user's responsibility to adjust this setting if the other intake rates are adjusted or terminated.

## 4.7.3 Percent Match Menu

### 4.7.3.1 Percent Match Setting

**Units:** percent

**Range:** 0 to 100 %

**Default:** 100% (balance)

The percent of the urine output that should be matched by hydration fluid. Touching the Default Percent Match button will reset the setting to the default value.

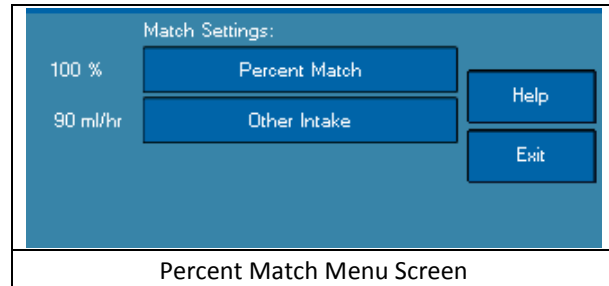

The Other Fluid Intake Setting is described in the previous section.

## 4.7.4 Alert Settings Menu

### 4.7.4.1 Minimum Urine Output Setting

**Units:** milliliters / hour

**Range:** 10 to 500 ml/hr

**Default:** 150 ml/hr

This setting provides the ability to monitor for the minimum desired urine output level (in ml/hr). If the urine output is consistently below the set value, the user will be notified by an alert sound and the display message: "Minimum Urine Level Not Reached". This is a monitoring setting only and does not affect the System's performance.

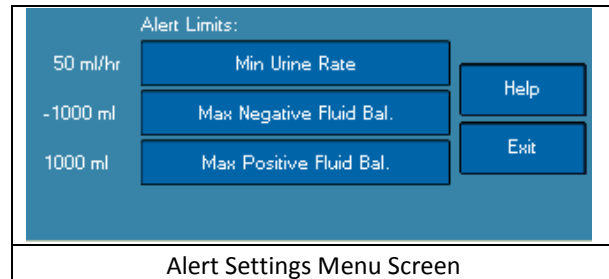

### 4.7.4.2 Negative Alert Limit Setting

**Units:** milliliters

**Range:** -100 to -9900 ml

**Default:** -1000 ml

This setting provides the ability to monitor for a negative fluid balance beyond a set limit. If the fluid balance drops below this level, the user is informed with an alert. This is a monitoring setting only and does not affect the System's performance.

### 4.7.4.3 Positive Alert Limit Setting

**Units:** milliliters

**Range:** 100 to 5000 ml

**Default:** 1000 ml

This setting provides the ability to monitor for a positive fluid balance beyond a set limit. If the fluid balance rises above this level, the user is informed with an alert. This is a monitoring setting only and does not affect the System's performance.

## 4.8 Initiation of Therapy

The RenalGuard System defaults to the matched hydration setting (Fluid Balance of 0 ml/hr). Other parameters are available (i.e. Bolus, Percent Match, and Desired Fluid Balance). See section 7 for information regarding these settings and parameters.

- Before starting therapy, check to ensure that:
  - all patient connections are secure,
  - the urine bag is hanging freely, and
  - the clamp on the infusion line is open.
- Press the **Run** button to start therapy.

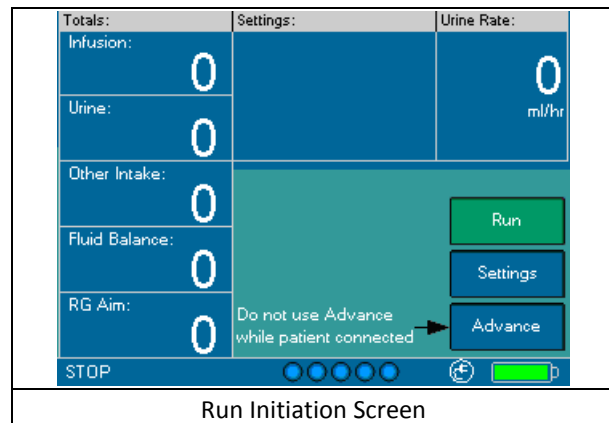

**Warning:** Running with the infusion line clamped or leaving the Console in Stop mode risks underinfusing the patient and increases the risk of thrombosis.

## 4.9 Using Pause Mode

The Pause Mode is similar to the KVO (Keep Vein Open) mode frequently used in IV therapy. It is intended to allow the urine collection bag to be drained or to Pause therapy while the patient is moved or urine drainage is re-arranged.

**Caution:** When the RenalGuard Console is in Pause mode, the Urine volume output is not being replaced. The Infusion rate is set to the minimum hydration rate until the user terminates Pause mode.

**Caution:** Stay in Pause mode no more than is necessary. After the urine bag is drained in Pause mode, urine is not measured by the Console until Run mode is resumed. Resume Run mode as soon as possible after draining bag to ensure accurate urine measurement.

- While in the Run Mode, press the **Pause** button to stop the urine volume replacement control.
  - While in the Pause mode, the System will run the pump at the minimum hydration rate to keep the vein open and to maintain minimum IV hydration.
  - During pause mode, the Console emits a low volume beeping. After 15 minutes, the Console will increase the volume of the beeping to high to alert the user that the patient is not receiving urine volume replacement.
- To resume Run mode operation, press the **Run** button.
- Upon exiting from the Pause mode and entering the Run mode, the Console adapts to the infusion and collection bag weight changes to correctly resume hydration control.

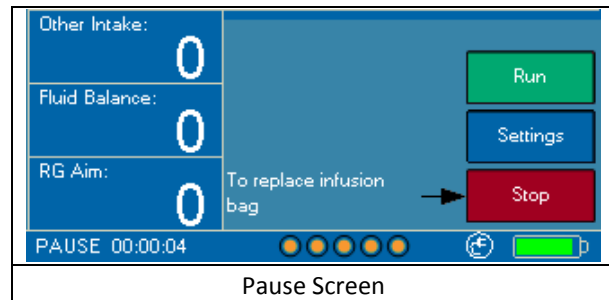
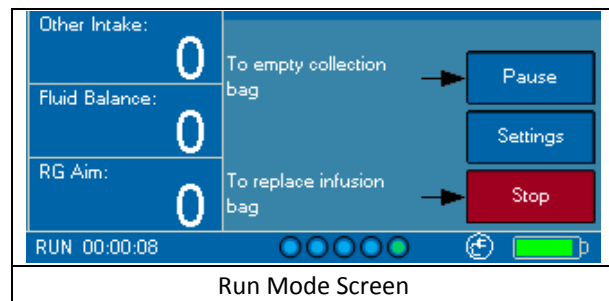

## 4.10 Using Advance Mode

The Advance mode runs the pump at 60 ml/min to allow air bubbles to be cleared from the Infusion Set. The **Advance** button can only be activated while the Console is in Stop mode.

**Warning:** Air detection is disabled during **Advance** button operation. The **Advance** button must not be pressed while the Infusion Set is connected to the patient.

- Press and hold the **Advance** button to run the pump to displace fluid and air through the infusion set. Once the **Advance** button is released, the pump will stop within 2 seconds.
- The pump will automatically stop when the **Advance** button has been depressed for 30 seconds. It will be necessary to release and then re-press the **Advance** button to run the pump for as long as an additional 30 seconds.

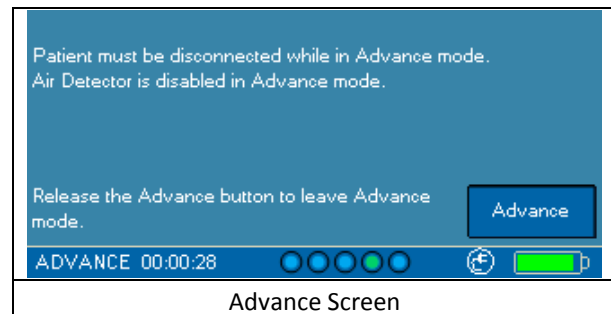
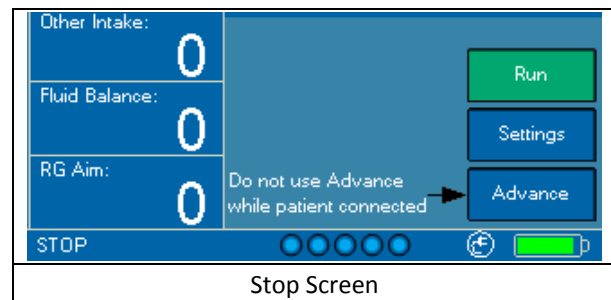

## 4.11 Replacing the Hydration Fluid Bag

**Caution:** The RenalGuard System is designed for use with 1 (one) liter infusion bags only. The System will not operate properly with other sized infusion bags.

**Warning:** The RenalGuard System is designed for hydration with crystalloid and colloid hydration fluids only. It is not designed to infuse blood, blood products, or to deliver drugs.

1. The RenalGuard System is designed to automatically stop and sound an alarm when the Hydration Bag is nearly empty (i.e., when approximately 50 ml of fluid remains in the bag). The message: "Infusion Bag Empty" will be displayed. This alarm can be silenced for a 2 minute period using the **Silence** button.
2. Press the **Clear Alarm** button to reset the alarm.
3. If a hydration bag that is not empty requires replacement, press the **Stop** button to stop the pump and avoid allowing air into the circuit.
4. Remove the hydration bag from the Left chain hook. Disconnect the Infusion Set spike from the hydration bag.

5. Using the standard technique, spike a fresh 1 liter hydration bag using the Infusion Set spike.
6. Facing the front of the Console, hang the full hydration bag on the left chain hook. Ensure that the bag hangs freely and that its motion will remain unobstructed as it empties.
7. Press the **Run** button to resume Therapy.
8. The RenalGuard Console will automatically account for any weight changes and will automatically replace urine output by the patient while the pump was stopped.

## 4.12 Emptying the Urine Collection Bag

**Caution:** Emptying the Urine Collection Bag during Run or Stop mode, or while the Console is powered off may result in incorrect urine measurement and alarms.

The Urine Collection Bag should only be emptied during Pause mode. Do not empty the Urine Collection Bag during Run or Stop mode, or while the Console is powered off. Accurate urine collection is a key component of RenalGuard Therapy. Draining the bag in any mode other than Pause may result in incorrect urine measurements and alarms.

There are two times the Urine Collection Bag emptying should be initiated:

- a. After the Console has reported the alert “Urine Bag Full”, or
- b. During Operation (Run mode) whenever the user chooses to empty the bag

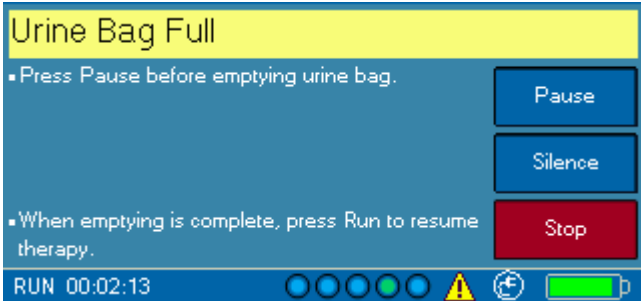
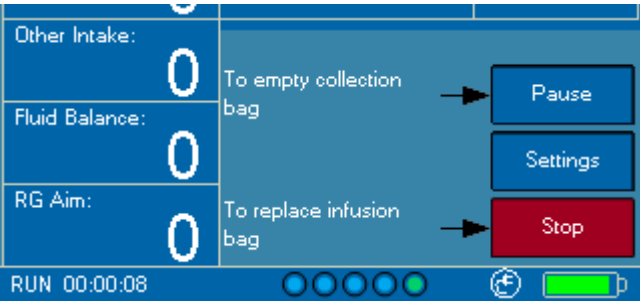
If the “Urine Bag Full” Alert is displayed:	During Operation:
	
<ol style="list-style-type: none"> <li>1.1 Press the <b>Pause</b> button to select the Pause Mode; this will also clear the alert.</li> <li>1.2 Empty the Urine Collection bag by opening the valve at the bottom and draining the bag in accordance with established procedures.</li> <li>1.3 When drainage is complete, close the urine collection bag drain valve.</li> <li>1.4 Press the <b>Run</b> button to resume Therapy.</li> </ol>	<ol style="list-style-type: none"> <li>2.1 Ensure that the Console is in the Run mode prior to emptying the Urine Collection bag.</li> <li>2.2 Press the <b>Pause</b> button to select the Pause Mode and clear the alert.</li> <li>2.3 Empty the urine Collection bag by opening the valve at the bottom and draining the bag in accordance with established procedures.</li> <li>2.4 When drainage is complete, close the urine collection bag drain valve.</li> <li>2.5 Press the <b>Run</b> button to resume Therapy.</li> </ol>
<p>Therapy will not restart until the <b>Run</b> button has been pressed</p>	

## 4.13 Conclusion of Therapy

1. Once therapy is complete, press the **Stop** button to stop Operation. Turn the RenalGuard Console off.
2. Remove the infusion set from the patient following your standard procedure for removing and IV.
3. Remove the infusion set from the RG console:
  - Disconnect the pressure transducer (labeled 4) from the RenalGuard console

Open pump head door and remove the tubing from the pump head

Remove the tubing from the air detect sensor

Take the infusion bag off its hook

4. Remove the patient's Foley catheter following your standard procedure to remove a Foley
5. Remove the Urine Collection Set line from the hose holder on the chain guide and remove the Urine Collection Set from the hook.
6. Discard the Infusion Set and the Urine Collection Set. Do not re-use.
7. Refer to section 4.2.4 for storage instructions and to section 4.2.5 for detailed battery charging instructions.

## 4.14 De-Installation and Packaging

This section details the steps followed to de-install the RenalGuard Console and to package the Console for shipment to RGS.

Contact service with any questions concerning the de-installation or return of Consoles. The numbers in parenthesis () refer to the identification numbers in the illustration and the table in section 4.1.

1. Set the On/Off switch (1) on the front of the Console to the "Off" position. Place a piece of tape over the switch to ensure that the switch will remain in the off position during shipment.
2. Disconnect the medical grade AC power cord from the power entry module (15) located at the rear of the Console. Place the power cord in the large plastic bag provided with the shipping box.
3. If the chains are attached to the Console by rings, it is a fixed-chain Console, proceed to step 4.

*Only for Consoles that do not have attached chains:*

- a) Remove the chain guide tubes (24) from the underside of the Console by unscrewing them in a counterclockwise direction. The chain guide tubes are 1 inch pieces of metal tubing located where the chains for the infusion and urine collection bags exit the Console.
  - b) Remove both the long (26) and short (25) chain assemblies from the underside of the Console by unscrewing their threaded ends in a counterclockwise direction. Place both chains and the two chain guide tubes in the small plastic bag provided with the shipping box.
4. Remove the Console from the pole by loosening the black pole clamp (19) at the rear of the Console. Ensure that the Console is adequately supported as you loosen the clamp.

5. Align the Console with the cutout foam in the shipping box. Place the Console into the foam in the box. The small plastic bag is intended to fit in the small foam cutout. The power cord fits into the open corner of the foam. If available the manual may be placed on top of the foam inside the box.
6. Ensure that the following components have been packed in the box:
  - RenalGuard Console
  - Short Infusion chain with hook
  - Long Urine chain with hook
  - 2 chain guide tubes (only with Consoles that do not have attached chains)
  - AC power cord
  - The operator's manual (if available)
7. Use shipping tape to seal the box. Follow the directions provided to return the product.
8. Do not return the cart with the Console.

## 4.15 Hourly Fluid Balance Table Screen

The hourly fluid balance table displays the following from left to right: The patient's total urine output, the total amount of infusion, the urine output in the last hour, the amount of infusion in the last hour and the hourly fluid balance. This data is collected and displayed at each hour. The time seen in the table is in military time and begins displaying data at the nearest hour after pressing run. The table will update every hour.

To enter the hourly fluid balance table screen from the run screen, press the top right corner of the run screen in the box that says, "Urine Rate". The hourly fluid balance table screen will appear for 2 minutes after entering the screen and then will automatically return to the run screen. Pressing the **Exit** button will return you back to your previous screen. Pressing **Stop** will stop the pump and return to "Stop Mode" screen.

Time	Total Urine	Total Infusion	Hour Urine	Hour Infusion	Hr. Fluid Balance
17:00	900	650	100	50	-50
16:00	800	600	100	50	-50
15:00	700	550	100	50	-50
14:00	600	500	150	100	-50
13:00	450	400	250	200	-50
12:00	200	200	100	100	0

## 5 Alarms and Troubleshooting

**Warning:** *Silencing and Clearing an Alarm may not eliminate the Alarm cause. Carefully investigate and correct all Alarms and Alerts.*

The alarms generated by the RenalGuard Console indicate the presence and severity of the condition detected. A high priority alarm will flash the alarm condition in red and produce a 10 beeps tone repeated every 15 seconds. A low Priority alert will display the alert condition in a constant yellow color and produce a 1 beep tone repeated every 15 seconds. The Alarm bell on the bottom of the display, as well as, the amount of beeps emitted by the Console represent the general level of importance of the current alarm condition to the user.

Pressing the **Silence** button will silence alarm for a 2 minute period while corrective actions are performed.

Respond to the information displayed on the screen and correct the conditions that caused the Alarm.

Press the **Clear Alarm** Button to reset the alarm.

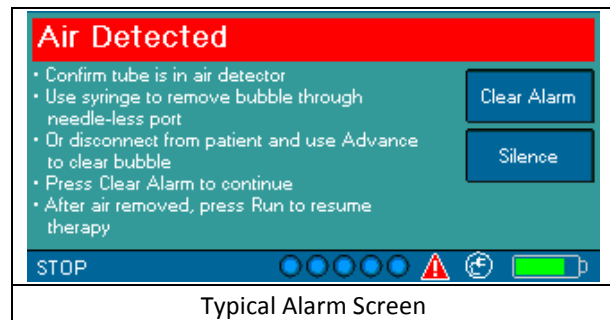

- If the Console is still in the Run Mode and the alarm condition is still present, the Alarm will re-annunciate.
- If Console is in the Stop Mode, the Alarm condition may be cleared but the Alarm will re-annunciate if the condition has not been removed when Run mode is restarted.

Certain Alarms such as System Malfunction Alarms cannot be cleared or silenced unless the Console power is turned OFF and then back ON.

Depending on the cause of an Alarm or Alert the RenalGuard Console may respond in one of three ways:

1. Inform the user and stop the pump  
(for example if air is detected or if the hydration fluid bag is almost empty)
2. Inform the user and stop urine volume replacement while maintaining pump flow at the minimum hydration rate. (For example, if the urine bag has excessive motion).
3. Inform the user and continue urine volume replacement.  
(For example, if the minimum urine rate has not been reached).

**Caution:** *While the RenalGuard Console will provide information on the most likely causes of the alarm, the user must exercise caution and examine all possible options if the information displayed does not solve the problem.*

## 5.1 Therapy Information Alerts

### Positive Fluid Balance Limit Reached (Low Priority)

This Alert is designed to inform the user that the positive fluid balance limit has been reached. This Alert is intended as an informational alert only and does not affect the System's operation.

This alert will recur after 15 minutes if the alert condition is still present.

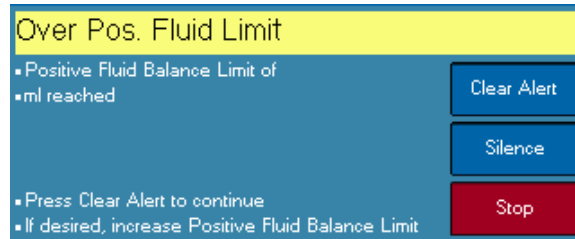

Alert Message Displayed

#### Recommended Action

1. Press the **Clear Alert** button to clear the alert
2. Confirm that current fluid balance is as desired
3. Adjust fluid balance settings (Desired Fluid Balance or Other Fluid Intake settings) if desired
4. Adjust Positive Fluid Balance Limit if desired (see section 4.7 for details).

### Negative Fluid Balance Limit Reached (Low Priority)

This Alert is designed to inform the user that the negative fluid balance limit has been reached. This Alert is intended as an informational alert only and does not affect the System's operation.

This alert will recur after 15 minutes if the alert condition is still present.

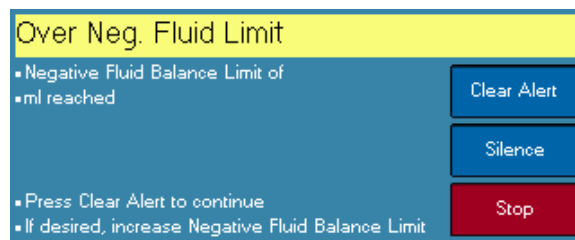

Alert Message Displayed

#### Recommended Action

1. Press the **Clear Alert** button to clear the alert
2. Confirm that current fluid balance is as desired
3. Adjust fluid balance settings (Desired Fluid Balance or Other Fluid Intake settings) if desired
4. Adjust Negative Fluid Balance Limit if desired (refer to section 4.7 for details).

### **Minimum Urine Not Reached (Low Priority)**

This Alert is designed to inform the user that over the previous 30 minutes the patient's urine output was below the user selected minimum level. This Alert is intended as an informational alert only and does not affect the System's operation.

This alert can also indicate blocked, kinked or clamped urine Collection Set. The user should check to ensure that the flow through the Collection Set flow is unobstructed.

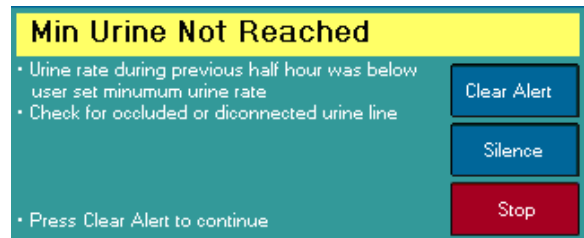

Alert Message Displayed

#### **Recommended Action**

1. Ensure that urine bag is hanging freely on the right hook
2. Check that the urine Collection Set is connected to the patient's Foley catheter
3. Ensure that the Collection Set is not blocked, kinked, or clamped
4. Press the **Clear Alert** button to clear the alert
5. Ensure the patient bed has not been lowered such that the level of the patient's bladder is not below the urine collection bag

## **5.2 Fluid Path Related Alarms and Alerts**

### **Air Detected Alarm (High Priority)**

Significant amount of air is detected by the ultrasonic air detection. The pump is stopped until the user initiates corrective action.

#### **This alarm can be caused by:**

1. Air entrained from the damaged or disconnected tubing
2. Air entrained from the drip chamber
3. Tubing dislodged from the air detector slot

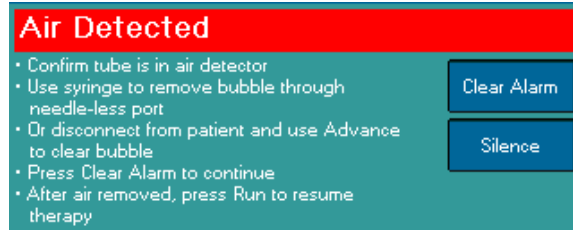

Alarm Message Displayed

#### **Recommended Action**

1. Check for leaks and confirm that the drip chamber level is correct
2. Use the Advance mode to remove or aspirate any air bubbles
3. Confirm that the tubing is properly placed in the air detector slot
4. Press the **Clear Alarm** button to clear the alarm
5. Restart therapy by pressing the **Run** button after removing any air bubbles

**Warning:** It is the user's responsibility to ensure that air is removed from the infusion circuit before the system is restarted following air detection.

**Warning:** Air detection and occlusion detection are disabled during **Advance** button operation. The **Advance** button must not be pressed while the Infusion Set is connected to the patient.

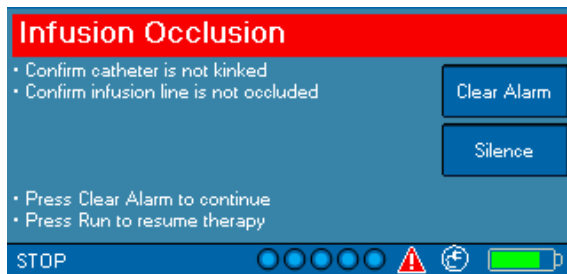
**Infusion Set Occlusion Alarm (High Priority)**      **Intermittent Occlusion Alert (Low Priority)**

Alarm Message Displayed

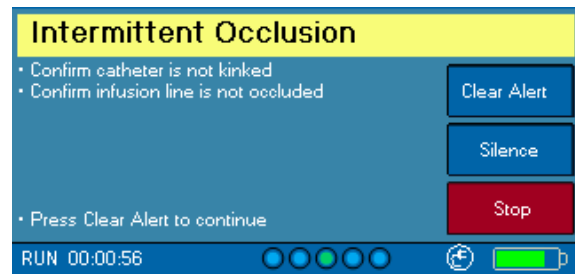

Alert Message Displayed

The pressure sensor has detected a downstream occlusion of the infusion line. If a full occlusion is detected an alarm is reported, a red flashing bar will be displayed, and the infusion pump is stopped pending corrective action. If an intermittent occlusion is detected an alert is reported, a yellow bar will be displayed, and the infusion pump will continue to operate.

**This alarm can be caused by:**

1. Closed clamp
2. Kinked tubing
3. Occluded IV

**Recommended Action**

1. Check clamps
2. Check tubing
3. Flush the IV in accordance with the accepted clinical technique
4. Press the Clear Alarm button to clear the alarm
5. Press the Run button to return the Console to the Run mode

**Urine Bag Full Alert (Low Priority)**

Using the weight scale, the Console has detected that the Urine Bag is full.

**Recommended Action**

1. Check the urine bag level
2. Press the **Pause** button to enter Pause mode and clear the Alert
3. Drain the urine bag in accordance with the accepted clinical technique
4. Close the urine bag drain valve
5. Press the **Run** button to return the Console to the Run mode

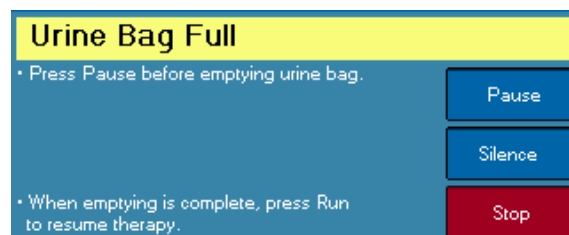

Alert Message Displayed

**Caution:** Always enter Pause mode prior to draining urine. Remember to close the drain valve. Press the **Run** button to resume therapy.

### **Infusion Bag Empty Alarm (High Priority)**

The system has detected that the Hydration Fluid Bag is almost empty. There can be approximately 50 ml of fluid left in the bag. The system automatically stops the hydration pump.

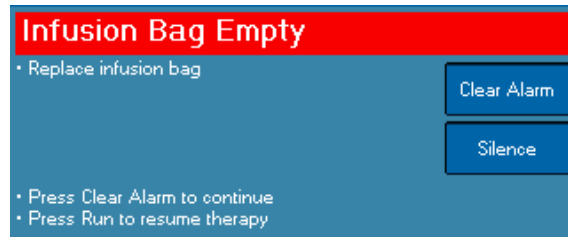

Alarm Message Displayed

#### **Recommended Action**

1. Check the fluid bag level
2. Replace the bag in accordance with the accepted clinical technique
3. Press the **Clear Alarm** button to clear the alarm
4. Press the **Run** button to return the system to the Run mode

### **Battery Low Alert (Low Priority) and Battery Very Low Alarm (High Priority)**

When there are fewer than 30 minutes of battery life remaining and the system is powered from the internal battery, the system generates an alert with a low volume and displays the message “Low Battery”.

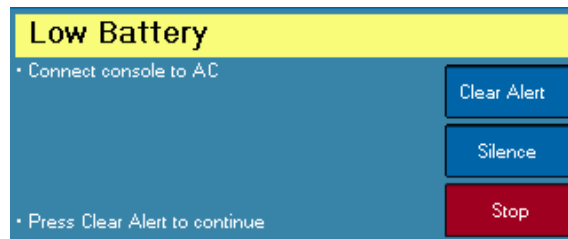

Alert Message Displayed

#### **Recommended Action**

1. Connect the Console to AC power
2. Refer to section 4.2.5 for detailed battery charging instructions
3. Press the **Clear Alert** button to clear the alert

When there are fewer than 3 minutes of battery life remaining and the system is powered from the internal battery, the system generates a flashing alarm with a high priority tone and flashes the message “Very Low Battery”. RG Console will enter stop mode and all infusing ceases until AC power is restored.

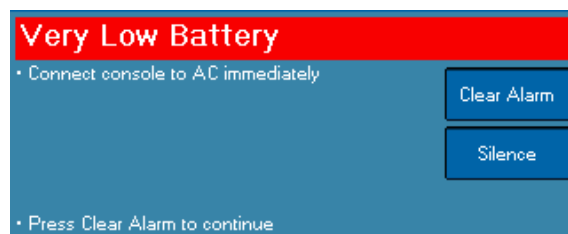

Alarm Message Displayed

#### **Recommended Action**

1. Connect the Console to AC power
2. Refer to section 4.2.5 for detailed battery charging instructions
3. Press the **Clear Alarm** button to clear the alarm
4. Press the **Run** button to return the system to the Run mode

### **Excessive Urine Weight Increase Alert (Low Priority)**

The system monitors Urine Weight for abrupt increases that cannot be explained by normal urine output. If an abrupt increase of urine weight is detected an Alert message is issued to the user. The Console automatically switches to the Pause mode. Hydration continues at the minimum hydration rate.

Urine volume replacement is disabled during

this time. The user can clear this alert. The user must press the **Pause** button to restart therapy. The excessive increase in urine weight is not included in the total urine measurement.

#### **This alert can be caused by:**

1. Object pulling on the urine scale hook
2. Additional weight added to urine bag
3. Hardware malfunction

#### **Recommended Action**

1. Ensure that the Urine collection bag is freely hanging on the right side hook
2. Press the **Clear Alert** button to clear the alert
3. Press **Run** button after correcting the condition to re-enter Run mode.

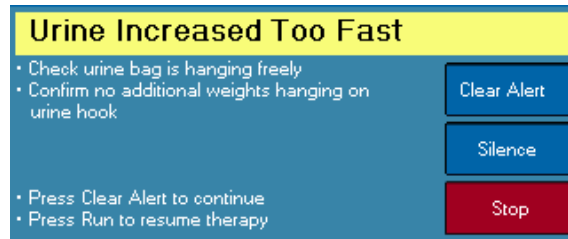

Alert Message Displayed

### **Urine Bag Leak Alert (Low Priority)**

The system monitors the urine bag for a decrease in weight. If such a decrease occurs during therapy an Alert is issued and the Console enters the Pause mode.

#### **This alert can be caused by:**

1. The urine bag was drained without pressing the **Pause** button
2. The urine bag is leaking

#### **Recommended Action**

1. Check for leaks
2. Check the tubing
3. Press the **Clear Alert** button to clear the alert
4. Press **Run** button to restart therapy.

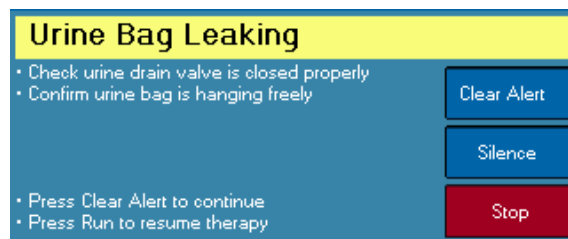

Alert Message Displayed

**Unstable Scale Alarms and Alerts (Low Priority)**

<p><b>Infusion Bag Moving</b></p> <ul style="list-style-type: none"> <li>Stabilize infusion bag</li> </ul> <p>• Press Clear Alert to continue</p> <p>Clear Alert</p> <p>Silence</p> <p>Stop</p>	<p><b>Urine Bag Moving</b></p> <ul style="list-style-type: none"> <li>Stabilize urine bag</li> </ul> <p>• Press Clear Alert to continue</p> <p>Clear Alert</p> <p>Silence</p> <p>Stop</p>
Alert Message Displayed	Alert Message Displayed
<p><b>Infusion Bag Moving</b></p> <ul style="list-style-type: none"> <li>Stabilize infusion bag</li> </ul> <p>• Press Clear Alarm to continue • Press Run to resume therapy</p> <p>Clear Alarm</p> <p>Silence</p>	<p><b>Urine Bag Moving</b></p> <ul style="list-style-type: none"> <li>Stabilize urine bag</li> </ul> <p>• Press Clear Alarm to continue • Press Run to resume therapy</p> <p>Clear Alarm</p> <p>Silence</p>
Alarm Message Displayed	Alarm Message Displayed

The system relies on weight scales to determine urine output and fluid replacement rate. If the device is excessively bumped, the weight scale readings become erratic and unreliable. The system automatically detects such conditions and issues an alarm. If the weight scale is not stable, the system will automatically enter the Pause mode.

Whenever the system is in the Pause mode, urine volume is not being replaced. Patient receives hydration fluid at the user set minimum hydration rate. When in the Pause mode, the Console will emit low rate and volume beeps. After 15 minutes, the system will increase the volume to high to bring to user's attention that the patient is receiving only the Minimum Hydration Rate of fluid.

If unstable scales are detected at the start of the Run mode, the Console issues an alarm and enters the Stop mode.

**This alarm can be caused by:**

- Excessive Motion

**Recommended Action****During the Start of Run**

- Bring the system to rest
- Press the **Clear Alarm** button to clear the alarm
- Press the **Run** button to start balancing

**During Operation**

- Bring the system to rest
- Press the **Clear Alarm** button to clear the alarm
- Press the **Run** button to restart balancing

**Caution:** Whenever the RenalGuard System is in the Pause mode, urine volume is not being replaced. The patient receives the user set minimum rate of hydration.

## **Infusion Weight Mismatch Alarm (High Priority)**

During patient hydration the system monitors the weight of the hydration fluid bag and compares it to the pump flow rate. If serious mismatch is detected an alarm is issued and the pump is stopped.

### **This alarm can be caused by:**

1. Disconnected Tube
2. Kinked tube or other type of pre-pump occlusion
3. Leaky bag or tube

### **Recommended Action**

1. Check for leaks
2. Check for occlusion
3. Press the **Clear Alarm** button to clear the alarm
4. Restart therapy if the condition is corrected by pressing the **Run** button

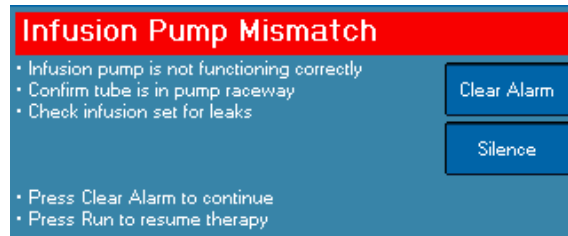

Alarm Message Displayed

## **Pump Door Open Alarm (High Priority)**

If the pump door is opened while the pump is running, the system generates a beep, displays an alarm message, and the pump is stopped.

If the pump door is opened when the pump is not running, a message indicating that pump door is open will be displayed. Whenever the Pump Door is opened, the pump rollers will not move and the pump will not run.

### **Recommended Action**

1. If Pump Door is open, close it
2. Press the **Clear Alarm** button to clear the alarm
3. Press the **Run** button to restart therapy.
4. If Pump Door is closed, cycle the power once. If the condition persists, notify service (refer to section 2.14 Service Information).

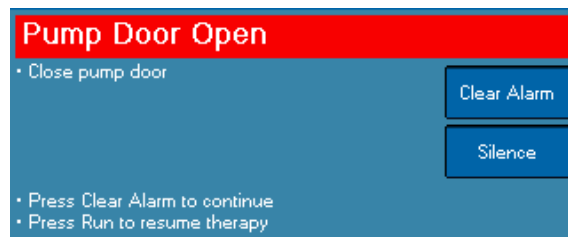

Alarm Message Displayed

**Pressure Sensor Disconnected Alarm (High Priority)**

If the pressure sensor is disconnected while pump is running, the system generates a beep, displays an alarm message, and the pump is stopped.

**This alarm can be caused by:**

1. Disconnected pressure sensor
2. Negative pressure in the infusion line

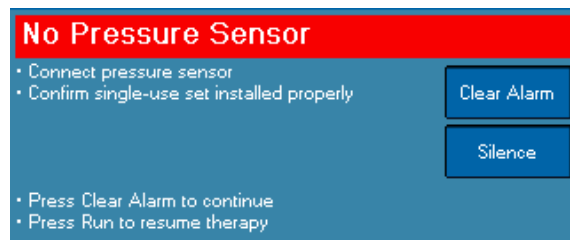

Alarm Message Displayed

**Recommended Action**

1. If pressure sensor is disconnected, connect it
2. Press the **Clear Alarm** button to clear the alarm
3. Press the **Run** button to restart therapy.
4. If pressure sensor is connected, check that Infusion Set is installed correctly.
5. If alarm persists, open and close the infusion pump door. If the condition remains, notify service (refer to section 2.14 Service Information).

**Prime Test Failure Alarms (Low Priority)**

<p><b>Weight Scale Test Failed</b></p> <ul style="list-style-type: none"> <li>• Confirm that single use set is installed correctly</li> </ul> <ul style="list-style-type: none"> <li>• Press Clear Alarm to re-try</li> </ul> <div style="text-align: center;"> <p><b>Clear Alarm</b></p> </div> <div style="text-align: right;"> <p><b>Silence</b></p> </div>	<p><b>Pressure Sensor Test Failed</b></p> <ul style="list-style-type: none"> <li>• Confirm that single use set is installed correctly</li> </ul> <ul style="list-style-type: none"> <li>• Press Clear Alarm to retry</li> </ul> <div style="text-align: center;"> <p><b>Clear Alarm</b></p> </div> <div style="text-align: right;"> <p><b>Silence</b></p> </div>
<p><b>Air Detector Test Failed</b></p> <ul style="list-style-type: none"> <li>• Confirm that single use set is installed correctly</li> <li>• Confirm that the tube is in the air detector</li> <li>• Confirm that the infusion bag is not empty</li> </ul> <ul style="list-style-type: none"> <li>• Press Clear Alarm to retry</li> </ul> <div style="text-align: center;"> <p><b>Clear Alarm</b></p> </div> <div style="text-align: right;"> <p><b>Silence</b></p> </div>	
<p>Alarm Messages Displayed</p>	

These alarms may occur at the end of priming. The system checks the performance of:

1. Weight scales by comparing them to each other
2. Pressure Sensor
3. Air Detector

If this test does not pass, patient therapy will not be allowed. The following messages above are displayed, including steps to correct prime performance.

**These alarms can be caused by:**

1. Incorrect connection of fluid path during priming
2. Bags not on hooks
3. Interference with weight scale measurements
4. Pressure sensor disconnected
5. Tubing not in the air detector slot
6. Hardware failure

**Recommended Action**

1. Ensure that the Infusion Set is connected to the Urine Collection bag
2. Ensure that Urine collection bag is freely hanging on the right side hook and the hydration fluid bag is freely hanging on the left side hook
3. Ensure that the tubing is correctly loaded into the pump.
4. Ensure that the pressure sensor is connected
5. Ensure tubing is in the air detector slot
6. Press the **Clear Alarm** button to clear the alarm
7. Repeat the procedure using the **Start Prime** button

**Infusion Bag Oversize Alarm (High Priority)**

If the weight of the infusion bag is greater than 1.5 Kg (larger than a standard 1 liter infusion bag) and the user attempts to go into Run mode, the system generates an audio alarm, displays an alarm message, and the pump is stopped.

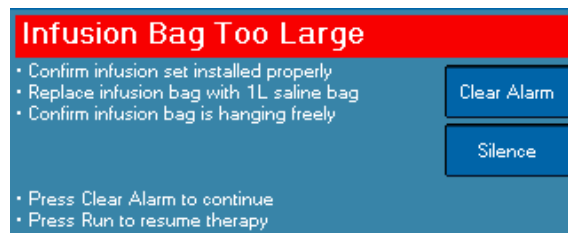

Alarm Message Displayed

**This alarm can be caused by:**

1. An infusion bag greater than 1 liter being placed on the Console.

**Recommended Action**

1. Check the infusion bag and ensure that only a 1 liter bag is on the weight scale.
2. Press the **Clear Alarm** button to clear the alert
3. Press the **Run** button to restart therapy.

### **Urine Bag Not Detected Alarm (High Priority)**

If the urine collection bag is not attached to the Console and the user attempts to go into the Run mode, the system generates an audio alarm, displays an alarm message, and the pump is stopped.

#### **This alert can be caused by:**

1. No urine collection bag attached to the Console.

#### **Recommended Action**

1. Check that the urine collection bag is properly attached on the weight scale
2. Press the **Clear Alarm** button to clear the alarm
3. Press the **Run** button to restart therapy.

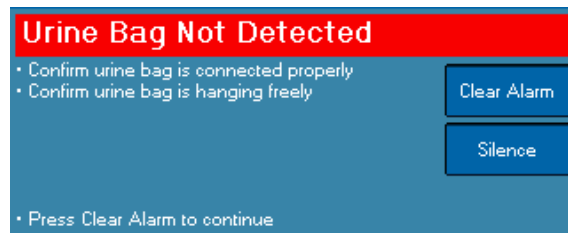

Alarm Message Displayed

### **Rapid Infusion Weight Decrease Alarm (Low Priority)**

The Console has detected that the weight of Hydration Fluid Bag decreased too rapidly. If such a decrease occurs during therapy, an Alarm is issued and the Console enters Pause mode.

#### **Recommended Action**

1. Check that the Hydration Fluid Bag is on the left hook.
2. Confirm that the Hydration Fluid Bag is connected properly and is not leaking
3. Press the **Clear Alarm** button to clear the alarm
4. Press the **Run** button to return the system to the Run mode

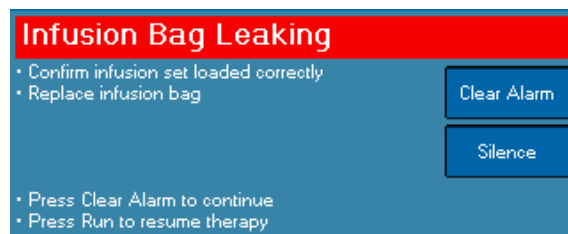

Alarm Message Displayed

## **5.3 System Malfunctions (High Priority)**

System malfunctions result from internal system diagnostic tests that are continuously executed while the Console is in operation. They typically indicate a possibility of a component malfunction.

An Alarm is issued and the pump is stopped. System Malfunctions cannot be cleared. The user is advised to turn the power off and then on once. If the system malfunction condition remains, the system should not be used.

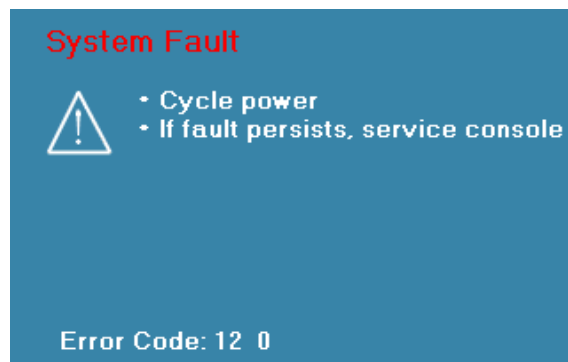

Fault Message Displayed

A system malfunction alarm may be accompanied by an error code. The user is advised to record the message and inform service (refer to section 2.14 Service Information).

## 6 Technical Information

### 6.1 Console Specifications

Feature	Description						
Model	FM1						
Dimensions	14 x 7 x 9 inches (35.6 x 17.8 x 22.9 cm) (H x W x D)						
Weight	9 lbs. (4.1 Kg)						
Max Working Load	The maximum weight that can be placed on the RenalGuard cart is 50 lbs. (22.7 Kg) Maximum load on the RG basket is 15 lbs. (6.8Kg)						
Main Voltage	100-240 VAC, 60/50 Hz AC connection with grounded chassis						
Power	100 VA						
Fuse	5A slow-blow 250V, 5 mm X 20 mm (type T5AH250V)						
Internal Battery	Power Failure Backup Only Type: Lithium Polymer 30 minutes minimum at intermediate flow or maximum flow Charge: 4 hours to rated capacity whenever plugged into AC outlet. For best results, the AC should be cycled every 2 hours during charging. Replacement of the internal battery should only be performed by qualified service technicians.						
Enclosure Leakage Current	< 300 uA Normal Condition < 500 uA Single Fault Condition						
Applied Parts	Infusion and Collection (Urine) Sets Type CF. Contact not to exceed 14 days						
Flow Rates	<table border="0"> <tr> <td>Minimum Hydration Rate/ KVO Rate</td> <td>10 ml /hr default, user adjustable from 10 – 100 ml/hr</td> </tr> <tr> <td>Normal Operating Rate</td> <td>10 to 3,000 ml/hr. Based on user setting and measured urine output.</td> </tr> <tr> <td>Maximum Flow Rate</td> <td>6000 ml/hr for up to 3 minutes.</td> </tr> </table>	Minimum Hydration Rate/ KVO Rate	10 ml /hr default, user adjustable from 10 – 100 ml/hr	Normal Operating Rate	10 to 3,000 ml/hr. Based on user setting and measured urine output.	Maximum Flow Rate	6000 ml/hr for up to 3 minutes.
Minimum Hydration Rate/ KVO Rate	10 ml /hr default, user adjustable from 10 – 100 ml/hr						
Normal Operating Rate	10 to 3,000 ml/hr. Based on user setting and measured urine output.						
Maximum Flow Rate	6000 ml/hr for up to 3 minutes.						

**Feature**

**Description**

Bolus Flow and Continuous Flow Accuracy

±15% of setting or ±75 ml whichever is greater.

Although the RenalGuard System injects fluid in response to urine flow, a bolus can be programmed for delivery in a 30 minute interval. The bolus can be set from 0 ml to 500 ml range in 50 ml increments. Bolus delivery accuracy for the 50 ml bolus setting is represented graphically in figure 1 for 25 replicate runs each. The extremes of the bolus delivery accuracy were found to be +11.5%, -11.4% for the 50 ml bolus. Bolus delivery accuracy for the 250 ml bolus setting is represented graphically in figure 2 for 25 replicate runs each. The extremes of the bolus delivery accuracy were found to be +2.0%, -5.3% for the 250 ml bolus setting.

All accuracy testing was performed with AC00050 RG Single Use Sets

**Figure 1 Histogram of Bolus Volume at 50 ml setting**

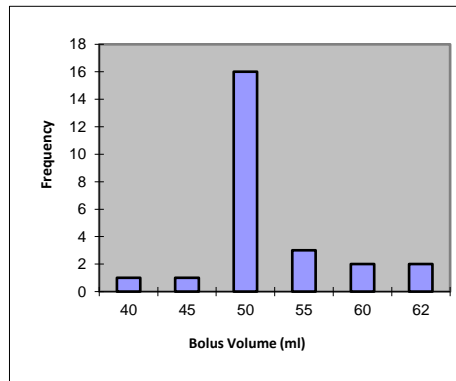

**Figure 2 Histogram of Bolus Volume at 250 ml setting**

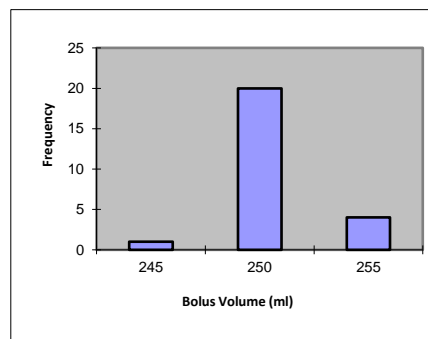

KVO / Pause

10 ml /hr default, user adjustable from 10 – 100 ml/hr

Maximum Infusion

Under single fault conditions, a maximum of 1 L of hydration fluid can be infused. The fault can only occur while the Console is in Stop mode and the user then transitions into Run mode. However, the System will alarm during this time and the total of 1 liter will take a minimum of 17 minutes to infuse.

<b>Feature</b>	<b>Description</b>
Downstream Occlusion	<p>Solid State Pressure Sensor.</p> <p>Alarm fixed at 15 psi. Maximum pressure 20 psi.</p> <p>At 50 ml/min, alert occurs within 45 s (<math>\pm</math> 15 s). When released, generates bolus volume of 6 ml (<math>\pm</math> 4 ml)</p> <p>At minimum flow, alert occurs within 3 minutes (<math>\pm</math> 1 minute)</p>
Air Detector	Ultrasonic (Detects 0.05 ml bubble at 100 ml/min)
Operating Conditions	<p>Temperature: 15°C to 40°C</p> <p>Humidity: 20%-85% non condensing</p>
Storage and Transport Conditions	<p>Temperature: -10°C to 45°C</p> <p>Humidity: 20%-85% non condensing</p>
Atmospheric Pressure	700hPa-1060hPa
Enclosure	Plastic and coated metal.
Drip Proof	Enclosure provides IPX2 protection against the ingress of vertical dripping water in accordance with IEC 60529
Non-Volatile Memory	User settings and therapy data are stored indefinitely in the RG System's memory
Calibration	The RenalGuard Console scales should be calibrated annually by qualified service technicians. See Section 2.8 Calibration Requirements.
Over-infusion Protection / Under-infusion protection	<p>The RenalGuard System uses two independent means to monitor the rate of fluid infusion to prevent over- or under- hydration.</p> <ul style="list-style-type: none"> <li>the RenalGuard Console monitors the pump speed to ensure accurate flow.</li> <li>the RenalGuard Console also monitors the change of weight in the infusion bag to add a redundant check of the hydration fluid infusion rate.</li> </ul>
Audible Alarm	Can be muted for 2 minutes. Sound pressure of alarms is 64.3 dBA +/- 10dBA. Alarm settings are stored in Non-volatile memory and remain indefinitely.
Expected Service Life	The expected service life of the RG console is 10 years
Essential Performance	<p>Bolus Flow Accuracy of device +/- 15% or +/- 75ml whichever is greater</p> <p>Continuous Flow Accuracy of Device +/- 15% or +/- 75ml whichever is greater</p> <p>Urine measurement and infusion accuracy combined error not to exceed +/- 15% or +/- 75ml whichever is greater</p>

## 6.2 Guidance and Manufacturer's Declaration

<b>Guidance and Manufacturer's Declaration – Emissions (for all equipment and systems)</b>
The RenalGuard Console is intended for use in the electromagnetic environment specified below. The customer or user of the RenalGuard Console should ensure that it is used in such an environment. AC00050 RG single use set was used for all IEC 60601-1- testing

<b>Emissions Test</b>	<b>Compliance</b>	<b>Electromagnetic Environment – Guidance</b>
RF Emissions CISPR 11	Group 1	The RenalGuard Console RF emissions are very low and are not likely to cause any interference in nearby electronic equipment.
RF Emissions CISPR 11	Class A	The RenalGuard Console is suitable for use in all establishments, including domestic, and those directly connected to the public low-voltage power supply network that supplies buildings used for domestic purposes. The RenalGuard Console has internal batteries which provide continued operation during power mains interruptions up to 30 minutes in duration.

<b>Guidance and Manufacturer's Declaration – Immunity (for all equipment and systems)</b>
The RenalGuard Console is intended for use in the electromagnetic environment specified below. The customer or user of the RenalGuard Console should ensure that it is used in such an environment. AC00050 RG Single Use Set was used for all IEC 60601-1- Testing

<b>Immunity Test</b>	<b>IEC 60601 Test Level</b>	<b>Compliance Level</b>	<b>Electromagnetic Environment – Guidance</b>
ESD IEC 61000-4-2	±8 kV Contact ±15 kV Air	±8 kV Contact ±15 kV Air	Floors should be wood, concrete or ceramic tile. If floors are synthetic, the r/h should be at least 30%
EFT IEC 61000-4-4	±2 kV Mains	±2 kV Mains	Mains power quality should be that of a typical commercial or hospital environment.
Surge IEC 61000-4-5	±1 kV Differential ±2 kV Common	±1 kV Differential ±2 kV Common	Mains power quality should be that of a typical commercial or hospital environment.
Voltage Dips/Dropout IEC 61000-4-11	>95% Dip for 0.5 Cycle  60% Dip for 5 Cycles  30% Dip for 25 Cycles  >95% Dip for 5 Seconds	>95% Dip for 0.5 Cycle  60% Dip for 5 Cycles  30% Dip for 25 Cycles  During the >95% Dip the EUT loses essential function.	Mains power quality should be that of a typical commercial or hospital environment. The RenalGuard Console has internal batteries which provide continued operation during power mains interruptions up to 30 minutes in duration.
Power Frequency 50/60Hz Magnetic Field IEC 61000-4-8	3A/m	3A/m	Power frequency magnetic fields should be that of a typical commercial or hospital environment.

Guidance and Manufacturer's Declaration – Emissions (for non Life-supporting Equipment and Systems)
The RenalGuard Console is intended for use in the electromagnetic environment specified below. The customer or user of the RenalGuard Console should ensure that it is used in such an environment. AC00050 RG Single Use Set was used for all IEC 60601-1- Testing

Immunity Test	IEC 60601 Test Level	Compliance Level	Electromagnetic Environment – Guidance
Conducted RF IEC 61000-4-6	3 Vrms 150 kHz to 80 MHz	V1=3 Vrms	Portable and mobile communications equipment should be separated from the RenalGuard Console by no less than the distances calculated/listed below:  D=(3.5/V1)(Sqrt P)
Radiated RF IEC 61000-4-3	3 V/m 80 MHz to 2.5 GHz	E1=3 V/m	D=(3.5/E1)(Sqrt P) 80 to 800 MHz  D=(7/E1)(Sqrt P) 800 MHz to 2.5 GHz  Where P is the max power in watts and D is the recommended separation distance in meters.  Field strengths from fixed transmitters, as determined by an electromagnetic site survey, should be less than the compliance levels (V1 and E1).  Interference may occur in the vicinity of equipment containing a transmitter.

Guidance – Recommended Separation Distances for the RenalGuard Console (for non Life-supporting Equipment and Systems)
The RenalGuard Console is intended for use in the electromagnetic environment in which radiated disturbances are controlled. The customer or user of the Console can help prevent electromagnetic interference by maintaining a minimum distance between portable and mobile RF Communications Equipment and the Console as recommended below, according to the maximum output power of the communications equipment.

Maximum Output Power (Watts)	Separation (m) 150 kHz to 80 MHz D=1.1667 (Sqrt P)	Separation (m) 80 MHz to 800 MHz D=1.1667 (Sqrt P)	Separation (m) 800 MHz to 2.5 GHz D=2.3333 (Sqrt P)
0.01	0.11667	0.11667	0.23333
0.1	0.36894	0.36894	0.73785
1	1.1667	1.1667	2.3333
10	3.6894	3.6894	7.3785

100	11.667	11.667	23.333
-----	--------	--------	--------

## 7 Warranty

1. RenalGuard Solutions (RGS), Inc. warrants its Products to be free from defects caused by faulty material and poor workmanship. Liability under warranty is limited to the obligation to repair, or to replace without charge, any part found to be defective under normal use and service within the time period below, provided:
  - a) RGS is promptly notified within the warranty period in writing upon discovery of such defects.
  - b) The original parts are returned to RGS on RenalGuard Solutions prior authorization, transportation charges prepaid.
  - c) Examination by RGS discloses to its satisfaction that such defects have not been caused by abuse after delivery.
  - d) Warranties shall not apply to items which have been repaired or altered by other than RGS or its Representatives.
2. The period of warranty for RGS products is 12 months from the date of shipment.
3. RGS makes no warranties except as herein set forth. The warranties stated herein are in lieu of all other warranties, express or implied, and of all other obligations or liabilities on the part of RGS, and RGS neither assumes nor authorizes any other person to assume for it any other liability. The purchaser expressly waives any right, claim or cause of action that might otherwise arise out of the purchase and use of RGS products or service. RGS shall not be liable for special or consequential damages or any nature with respect to any merchandise or service sold, delivered or rendered.
4. All above warranties are contingent upon proper use of the Product. This warranty will not apply if:
  - a) Adjustment, repair or parts replacement is required because of accidental, unusual physical, electrical or electromagnetic stress, neglect, misuse, failure of electric power, air-conditioning, humidity control, improper storage, transportation or causes other than ordinary use, or;
  - b) if the Products have been modified without the prior written approval of RGS, or;
  - c) where RGS serial numbers or warranty date decals have been removed or altered, or;
  - d) where damage has occurred as the result of attaching accessories to the Product other than those approved by RGS, or;
  - e) where damage has occurred as a result of not using an uninterrupted power supply (UPS) where specified by RGS, or;
  - f) where damage has occurred as a result of not following the RGS operator's manual.